

HP 83236B
PCS Interface
Operating Manual

Serial Numbers

This manual applies directly to instruments with serial number prefix 3711J. For additional important information about serial numbers, see Serial Numbers on page 144.

HP Part No. 83236-90102
Printed in Japan
October 1997

3rd Edition

Copyright © Hewlett-Packard Company 1996, 1997

Notice

Information contained in this document is subject to change without notice.

This document contains proprietary information that is protected by copyright. All rights are reserved. No part of this document may be photocopied, reproduced, or translation to another language without the prior written consent of Hewlett-Packard Company.

Hewlett-Packard Japan, Ltd.
Kobe Instrument Division
1-3-2, Murotani, Nishi-ku, Kobe-shi,
Hyogo, 651-22 Japan

**Manual
Printing
History**

The manual printing and part number indicate its current edition. The printing date changes when a new edition is printed. (Minor corrections and updates that are incorporated at reprint do not cause the date to change.) The manual part number changes when extensive technical changes are incorporated.

November 1996.....	1st Edition
March 1997	2nd Edition
October 1997.....	3rd Edition

Certification	Hewlett-Packard Company certifies that this product met its published specifications at the time of shipment from the factory. Hewlett-Packard further certifies that its calibration measurements are traceable to the United States National Institute of Standards and Technology, to the extent allowed by the Institution's calibration facility, or to the calibration facilities of other International Standards Organization members.
Warranty	<p>This Hewlett-Packard instrument product is warranted against defects in material and workmanship for a period of one year from the date of shipment, except that in the case of certain components listed in Specifications of this manual, the warranty shall be for the specified period. During the warranty period, Hewlett-Packard Company will, at its option, either repair or replace products which prove to be defective.</p> <p>For warranty service or repair, this product must be returned to a service facility designated by HP. Buyer shall prepay shipping charges to HP and HP shall pay shipping charges to return the product to Buyer. However, Buyer shall pay all shipping charges, duties, and taxes for products returned to HP from another country.</p> <p>HP warrants that its software and firmware designated by HP for use with an instrument will execute its programming instruction when properly installed on that instrument. HP does not warrant that the operation of the instrument, or software, or firmware will be uninterrupted or error free.</p>
Limitation Of Warranty	The foregoing warranty shall not apply to defects resulting from improper or inadequate maintenance by Buyer, Buyer-supplied software or interfacing, unauthorized modification or misuse, operation outside of the environmental specifications for the product, or improper site preparation or maintenance. <i>No other warranty is expressed or implied. HP specifically disclaims the implied warranties of merchantability and fitness for a particular purpose.</i>
Exclusive Remedies	<i>The remedies provided herein are buyer's sole and exclusive remedies. HP shall not be liable for any direct, indirect, special, incidental, or consequential damages, whether based on contract, tort, or any other legal theory.</i>
Assistance	<p>Product maintenance agreements and other customer assistance agreements are available for Hewlett-Packard products.</p> <p>For any assistance, contact your nearest Hewlett-Packard Sales and Service Office. Addresses are provided at the back of this manual.</p>

Safety Summary

The following general safety precautions must be observed during all phases of operation, service, and repair of this instrument. Failure to comply with these precautions or with specific WARNINGS elsewhere in this manual may impair the protection provided by the equipment. In addition it violates safety standards of design, manufacture, and intended use of the instrument. *The Hewlett-Packard Company assumes no liability for the customer's failure to comply with these requirements.*

NOTE:

HP 83236B complies with INSTALLATION CATEGORY II and POLLUTION DEGREE 2 in IEC1010-1. HP 83236B is an INDOOR USE product.

NOTE:

LEDs in the HP 83236B are Class 1 in accordance with IEC 825-1.

CLASS 1 LED PRODUCT

Ground the Instrument

To avoid electric shock hazard, the instrument chassis and cabinet must be connected to a safety earth ground by the supplied power cable with earth blade.

DO NOT Operate In An Explosive Atmosphere

Do not operate the instrument in the presence of flammable gasses or fumes. Operation of any electrical instrument in such an environment constitutes a definite safety hazard.

Keep Away From Live Circuits

Operating personnel must not remove instrument covers. Component replacement and internal adjustments must be made by qualified maintenance personnel. Do not replace components with the power cable connected. Under certain conditions, dangerous voltages may exist even with the power cable removed. To avoid injuries, always disconnect power and discharge circuits before touching them.

DO NOT Service Or Adjust Alone

Do not attempt internal service or adjustment unless another person, capable of rendering first aid and resuscitation, is present.

DO NOT Substitute Parts Or Modify Instrument

Because of the danger of introducing additional hazards, do not install substitute parts or perform unauthorized modifications to the instrument. Return the instrument to a Hewlett-Packard Sales and Service Office for service and repair to ensure that safety features are maintained.

Dangerous Procedure Warnings

Warnings, such as the example below, precede potentially dangerous procedures throughout this manual. Instructions contained in the warnings must be followed.

WARNING:

Dangerous voltages, capable of causing death, are present in this instrument. Use extreme caution when handling, testing, and adjusting this instrument.

Safety Symbols

General definitions of safety symbols used on equipment or in manuals are listed below.



Instruction manual symbol: the product is marked with this symbol when it is necessary for the user to refer to the instruction manual.



Alternating current.



Direct current.



On (Supply).



Off (Supply).



In position of push-button switch.



Out position of push-button switch.

WARNING:

This WARNING sign denotes a hazard. It calls attention to a procedure, practice, condition or the like, which, if not correctly performed or adhered to, could result in injury or death to personnel.

CAUTION:

This CAUTION sign denotes a hazard. It calls attention to a procedure, practice, condition or the like, which, if not correctly performed or adhered to, could result in damage to or destruction of part or all of the product.

NOTE:

NOTE denotes important information. It calls attention to a procedure, practice, condition or the like, which is essential to highlight.

DECLARATION OF CONFORMITY

according to ISO/IEC Guide 22 and EN 45014

Manufacturer's Name: Hewlett-Packard Japan, LTD.
Manufacturers Address: 1-3-2, Murotani, Nishi-ku, Kobe-shi,
Hyogo, 651-22 Japan

declares, that the product

Product Name: PCS Interface

Model Number: HP 83236B

Product Options: This declaration covers all options of the above product.

conforms to the following Product Specifications:

Safety: IEC 1010-1:1990+A1:1992 / EN 61010-1:1993

EMC: EN 55011:1991 / CISPR 11:1990 - Group 1, Class A ¹⁾
EN 61000-3-3:1995 / IEC 1000-3-3:1994
EN 50082-1:1992

/IEC 801-2:1991 - 4 kV CD, 8 kV AD

/IEC 801-3:1984 - 3 V/m

/IEC 801-4:1988 - 0.5 kV Signal Lines, 1 kV Power Lines

Supplementary Information:

The product herewith complies with the requirements of the Low Voltage Directive 73/23/EEC and the EMC Directive 89/336/EEC and carries the CE marking accordingly.

LEDs in this product are Class 1 in accordance with IEC 825-1.

1) The product was tested in a typical configuration.

Kobe, March 3, 1997

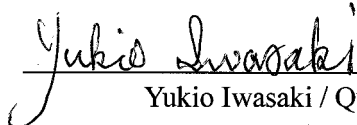

Yukio Iwasaki / Quality Manager

European Contact: Your local Hewlett-Packard Sales and Service Office or Hewlett-Packard GmbH.
Department HQ-TRE, Herrenberger Straße 130, D-7030 Böblingen (Fax: +49-7031-14-3143).

Herstellerbescheinigung

GERXUSCHEMISSION

LpA < 70 dB
am Arbeitsplatz
normaler Betrieb
nach DIN 45635 T. 19

Manufacturer's Declaration

ACOUSTIC NOISE EMISSION

LpA < 70 dB
operator position
normal operation
per ISO 7779

In this Manual This manual describes general information, function, operation, and specifications of the HP 83236B PCS Interface. The following chapters are included in this manual.

Chapter 1, General Information

This chapter provides a product overview and describes the furnished accessories, options, and front and rear panels.

Chapter 2, Installation

This chapter describes the steps for configuring the PCS Interface.

Chapter 3, Programming the PCS Interface

This chapter describes how to control the PCS Interface using HP-IB commands.

Chapter 4, HP-IB Commands

This chapter describes the remote operation of the PCS Interface using HP-IB.

Chapter 5, Specifications

This chapter describes the specifications of the PCS Interface.

Appendix A, Frequency Conversion Tables

Appendix A provides the frequency conversion tables used internally by the PCS Interface's CPU to determine the Test Set's frequencies.

Appendix B, Manual Changes

Appendix B provides a manual change history and information about serial numbers.

Error Messages

This section describes the error messages generated by the PCS Interface.

Glossary

This section defines terms used throughout this manual.

Contents

1 General Information

Introduction	16
Incoming Inspection	18
Furnished Accessories	19
Power Cable	20
Options	22
Front Panel	24
Rear Panel	26
Other Information	29

2 Installation

Introduction	32
When Used with HP 8924C and Controlled via Serial Port for CDMA Subscriber Unit Tests	34
When Used with HP 8924C and Controlled via HP-IB for CDMA Subscriber Unit Tests	37
When Used with HP 8920B and Controlled via Serial Port for TDMA Subscriber Unit Tests	40
When Used with HP 8920A,B and Controlled via HP-IB for TDMA Subscriber Unit Tests	45
When Used with HP 8921A for CDMA Base Stations Tests	50
When Used with HP 8921A for TDMA Base Stations Tests	54

Contents

Load and Run the Connectivity Test Software (Option 001 or 002) 59

Where to go next 64

3 Programming the PCS Interface using HP-IB Control

Introduction 66

Overview of Programming Issues 67

PCS Interface Programming Guide 75

Test Procedure Flow 76

Initialize the System 77

Set Up and Measure 79

4 HP-IB Commands

Introduction 92

The Syntax of Program Messages 94

Common Commands 98

COMPensation Subsystem 100

RF Subsystem 106

RX Subsystem 108

SYSTEM Subsystem 113

TX Subsystem 114

Contents

HP-IB Command Summary 121

5 Specifications

Introduction 124

Generator Output Path 125

Analyzer Input Path 128

Reference Specifications 131

Remote Control 131

Connectors 132

General Characteristics 135

A Frequency Conversion Tables

138

B Manual Changes

Introduction 142

Manual Changes 143

Serial Numbers 144

Change 1 145

Error Messages

Contents

Glossary 161

Index 163

General Information

What's included in this chapter:

- Introduction
- Furnished Accessories
- Options
- Front Panel
- Rear Panel

Introduction

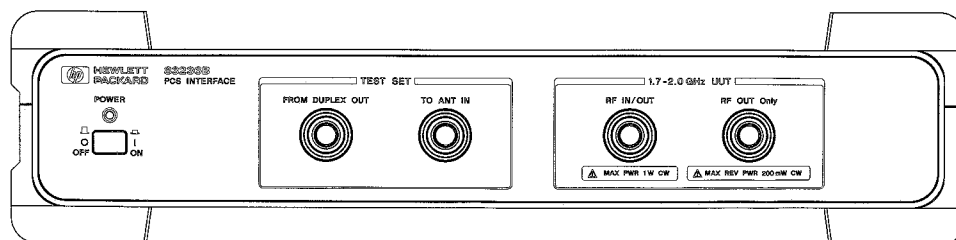

Figure 1 HP 83236B PCS Interface

The HP 83236B PCS Interface extends the time division multiple access (TDMA) and code division multiple access (CDMA) measurement capability of the HP 8920A,B, HP 8921A, and HP 8924C Test Sets to the 1710 to 1990 MHz frequency range. This frequency range covers the International (1710 to 1880 MHz), Korean (1715 to 1870 MHz), and North American (1850 to 1990 MHz) Personal Communications Service (PCS) bands. Table 1 shows the supported equipment combinations and the type of unit-under-test (UUT).

Table 1 Supported configuration and UUTs

UUT Type	Test Set	Cellular Adapter	
		International, Korea, and North American PCS Bands	North American PCS Band only
TDMA Base Station	HP 8921A	HP 83204A ¹	HP 83201A
TDMA Subscriber Unit	HP 8920A,B	HP 83206A ²	HP 83201A ^{3,B4}
CDMA Base Station	HP 8921A	HP 83203B or HP 83205A ⁵	—
CDMA Subscriber Unit	HP 8924C	Not required	

- 1.The combination of the HP 8921A and the HP 83204A composes the HP 8921A option 500.
- 2.Can be used with HP 8920B only. The combination of the HP 8920B and the HP 83206A composes the HP 8920B option 800.
- 3.The combination of the HP 8920A and the HP 83201A composes the HP 8920D.
- 4.The combination of the HP 8920B and the HP 83201B composes the HP 8920B option 500.
- 5.The combination of the HP 8921A and the HP 83205A composes the HP 8921A option 600.

Power measurement accuracy and speed are maintained at PCS band frequencies with an internal power meter for measurements on CW, CDMA, and TDMA signals.

The PCS Interface has no front panel “controls” and cannot be used manually. Control of the PCS Interface is via HP-IB using an external controller or the Test Set’s internal IBASIC controller, or via the serial port by the HP 8924C whose firmware revision is A.05.00 and above or HP 8920B option 800 whose firmware revision is B.05.00 and above.

Most of this manual is dedicated to assisting you in the integration, HP-IB programming, and control of the PCS Interface.

NOTE:

Refer to the *HP 8924C User’s Guide* or *HP 8920B User’s Guide* for the operation of the HP 83236B controlled via the serial port.

Conventions Used

The HP 83236B PCS Interface can be used with a variety of Test Sets and a variety of Cellular Adapters.

- Test Sets
 - HP 8920A, B
 - HP 8921A
 - HP 8924C
- Cellular Adapters
 - HP 83201A,B
 - HP 83203B
 - HP 83204A
 - HP 83205A
 - HP 83206A

To simplify things, the term Test Set will be used throughout this manual to refer to any HP 892NX, the term Cellular Adapter to refer to any HP 8320NX, and the term PCS Interface to refer to the HP 83236B PCS Interface. The combination of the Test Set, Cellular Adapter, and PCS Interface will be referred to as the Test System.

In some instances, TX will be used in place of the word transmitter, and RX will be used in place of the word receiver; UUT will be used as an abbreviation for unit-under-test.

Incoming Inspection

WARNING:

To avoid hazardous electrical shock, do not turn on the PCS Interface when there are signs of shipping damage to any portion of the outer enclosure (for example, covers, panel, or display).

Inspect the shipping container for damage. If the shipping container or cushioning material is damaged, it should be kept until the contents of the shipment have been checked for completeness and the PCS Interface has been checked mechanically and electrically. The contents of the shipment should be as listed in table 2 on page 19. If the contents are incomplete, if there is mechanical damage or defect, or if the system does not pass the power-on self tests, notify the nearest Hewlett-Packard office. If the shipping container is damaged, or the cushioning material shows signs of unusual stress, notify the carrier as well as the Hewlett-Packard office. Keep the shipping materials for the carrier's inspection.

Furnished Accessories

The following accessories are furnished with the PCS Interface.

Table 2

Included Accessories

Name	Qty.	Part/Product Number
HP-IB Cable (0.5 m)	1	HP 10833D
Serial Cable	1	HP p/n 83236-61609
N-BNC Cable	2	HP p/n 83236-61603
SMA-SMC Cable	1	HP p/n 83215-61643
SMC-SMC Cable	1	HP p/n 83215-61644
BNC-BNC Cable	1	HP p/n 8120-1839
BNC L-type adapter	2	HP p/n 1250-0076
BNC T-type adapter	1	HP p/n 1250-0781
Operation Manual (this manual)	1	HP p/n 83236-90102
Read Me First — Cable Connections for the PCS Interface	1	HP p/n 83236-90130
Front Cover	1	HP p/n 83201-61013
Power Cable ¹	1	

1. The part number depends on where the instrument is used, see "Power Cable" on page 20.

Power Cable

In accordance with international safety standards, this instrument is equipped with a three-wire power cable. When connected to an appropriate ac power outlet, this cable grounds the instrument frame. The type of power cable shipped with each instrument depends on the country of destination. Refer to figure 2 on page 21 for the part numbers of the power cables available.

WARNING: For protection from electrical shock, the power cable ground must not be defeated. The power plug must be plugged into an outlet that provides a protective earth ground connection.

<p>OPTION 900 United Kingdom</p>  <p>Plug : BS 1363A, 250V Cable : HP 8120-1351</p>	<p>OPTION 901 Australia / New Zealand</p>  <p>Plug : NZS8 198/AS C112, 250V Cable : HP 8120-1369</p>
<p>OPTION 902 European Continent</p>  <p>Plug : CEE 7/16, 250V Cable : HP 8120-1689</p>	<p>OPTION 903 U.S. / Canada</p>  <p>Plug : NEMA 5-15P, 125V, 15A Cable : HP 8120-1378</p>
<p>OPTION 904 U.S. / Canada</p>  <p>Plug : NEMA 6-15P, 250V, 15A Cable : HP 8120-0698</p>	<p>OPTION 905* Any country</p>  <p>Plug : CEE 22-VI, 250V Cable : HP 8123-1396</p>
<p>OPTION 906 Switzerland</p>  <p>Plug : SEV 1011.1959-24507 Type 12, 250V Cable : HP 8120-2104</p>	<p>OPTION 912 Denmark</p>  <p>Plug : DILCR 107, 220V Cable : HP 8120-2956</p>
<p>OPTION 917 India / Republic of S.Africa</p>  <p>Plug : SABS 164, 250V Cable : HP 8120-4211</p>	<p>OPTION 918 Japan</p>  <p>Plug : JIS C 8303, 125V, 15A Cable : HP 8120-4753</p>
<p>NOTE: Each option number includes a 'family' of cords and connectors of various materials and plug body configurations (straight, 90° etc.).</p> <p>* Plug option 905 is frequently used for interconnecting system components and peripherals.</p>	

Figure 2 Power Cable Supplied

Options

The following options can be used with the PCS Interface.

- 001** Utility Software on PCMCIA Card
- 002** Utility Software on EPSON Memory Card
- 1AB** Bench Top Kit
- AX4** Rack Flange Kit

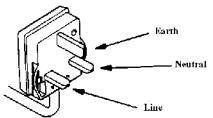
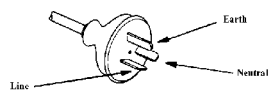
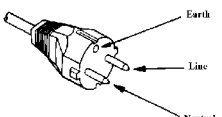
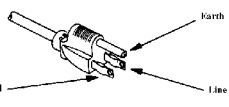
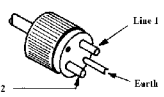
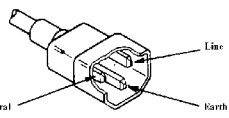
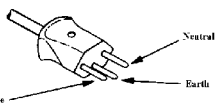
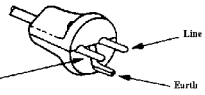
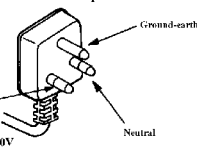
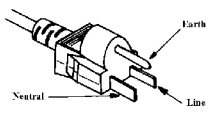
Option 001 — Utility Software on PCMCIA Card

Provides the Utility Software memory card which includes the Manual Control and Connectivity Test Programs (for HP 8920B and HP 8924C). N(f)-BNC(m) adapter and N(m)-BNC(f) adapter are also provided for the Connectivity Test Program.

Table 3

Included Accessories (Option 001)

Name	Qty.	Part/Product Number
Utility Software	1	HP p/n 83236-61002
N(f)-BNC(m) Adapter	1	HP p/n 1250-2789
N(m)-BNC(f) Adapter	1	HP p/n 1250-0780
Manual Control Software User's Guide	1	HP p/n 83236-90110

Option 002 — Utility Software on EPSON Memory Card

Provides the Utility Software memory cards which include the Manual Control, Connectivity, and CDMA/PCS Base Station Test Programs (for HP 8920A and HP 8921A). N(f)-BNC(m) adapter and N(m)-BNC(f) adapter are also provided for the Connectivity Test Program.

Table 4 **Included Accessories (Option 002)**

Name	Qty.	Part/Product Number
Utility Software	1	HP p/n 83236-61001
N(f)-BNC(m) Adapter	1	HP p/n 1250-2789
N(m)-BNC(f) Adapter	1	HP p/n 1250-0780
Manual Control Software User's Guide	1	HP p/n 83236-90110
CDMA/PCS Base Station Test Software User's Guide	1	HP p/n 83236-90121

Option 1AB — Bench Top Cabinet Kit

This kit is used to stack a 19-inch-wide instrument, such as the HP 8924C CDMA Mobile Station Test Set, on the HP 83236B. Rack mounting hardware is included.

For the instructions on how to mount the PCS Interface, refer to the *HP 83236A,B PCS Interface Option 1AB Bench Top Kit Installation Instruction* included with the kit.

Table 5 **Included Accessories (Option 1AB)**

Name	Qty.	Part/Product Number
Bench Top Cabinet Kit	1	HP p/n 83236-60022

Option AX4 — Rack Flange Kit

This kit mounts the instrument in a rack with 482.6 mm (19 in) spacing.

For the instructions on how to rack mount the PCS Interface, refer to the *HP 83236A,B PCS Interface Option AX4 Rack Flange Kit Rack Mount Installation Instructions* included with the kit.

Table 6 **Included Accessories (Option AX4)**

Name	Qty.	Part/Product Number
Rack Flange Kit	1	HP p/n 83236-60021

 **Front Panel**

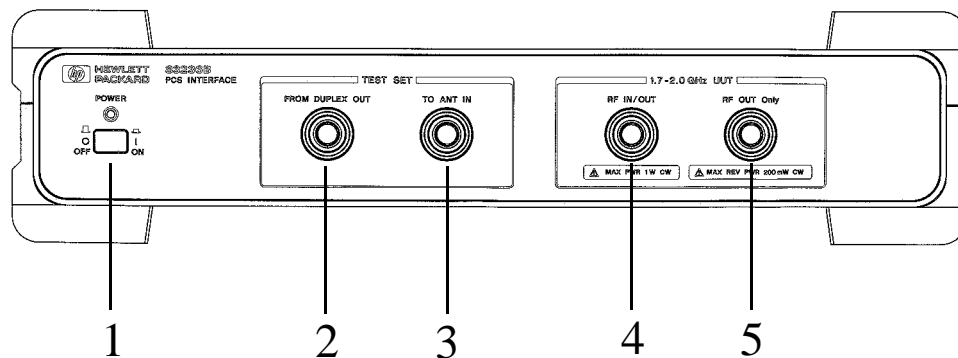

Figure 3 Front Panel

- 1. Line Switch** The power switch. The On position is | and the Off position is O. In the On position, power is supplied and the indicator above the switch is lit.
- 2. FROM DUPLEX OUT** Connects to the DUPLEX OUT port of a Test Set. (Connector type: Type N (F))
- 3. TO ANT IN** Connects to the ANT IN port of a Test Set. (Connector type: Type N (F))



4. RF IN/OUT

Connects to the transmit/receive antenna port of a radio.
(Connector type: Type N (F))

CAUTION:

The maximum allowable average power to the RF IN/OUT port depends on the unit-under-test as follows. Use an external attenuator if you are uncertain.

Subscriber Unit Test

Single carrier TDMA and FM:	10 Watts
CDMA:	5 Watts

Base Station Test

Single carrier TDMA and FM:	10 Watts
CDMA:	1 Watt

CAUTION:

Peak instantaneous signals greater than 30 volts will damage internal circuitry.



5. RF OUT only

Connects to the receive antenna port of a radio. (Connector type: Type N (F))

CAUTION:

Do not input a continuous signal greater than +23 dBm (200 mW). Doing so may damage internal circuits.

Rear Panel

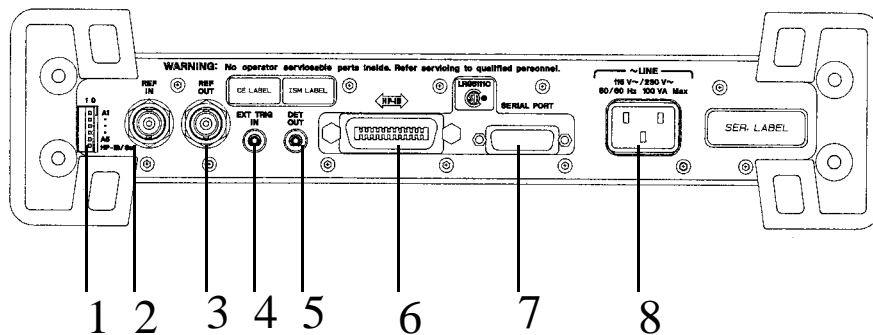

Figure 4 Rear Panel

- 1. HP-IB Address Selector** The HP-IB address selector specifies the HP-IB interface address (switches A1 to A5). The **HP-IB/Ser** switch sets whether the HP-IB port or SERIAL PORT is used to control the PCS Interface.
- 2. REF IN** Reference frequency input port. The REF IN port connects to the 10 MHz reference source. (Connector type: BNC (F))
- 3. REF OUT** Reference frequency output port. The REF OUT port may be used as a 10 MHz source for other equipment. (Connector type: BNC (F))
- 4. EXT TRIG IN** External trigger input. EXT TRIG IN is used to trigger power measurements of TDMA bursted signals. It connects to the FRAME CLK OUT port of the Cellular Adapter when the UUT is the TDMA type. (Connector type: SMC (M))
- 5. DET OUT** Detector output. DET OUT can be used for power measurements of CDMA subscriber units. (Connector type: SMC (M))

6. HP-IB Interface The HP-IB interface connects to an external controller to enable the control of the PCS Interface. In most cases, this control is provided by a Test Set.

NOTE:

To enable this HP-IB Interface, set the **HP-IB/Ser** switch of the HP-IB Address Selector to the “HP-IB” side (left side as viewed from the rear panel).

This interface conforms to IEEE 488.2 and has the following functions:

Table 7

HP-IB Functions

Codes	Functions
SH1	Full source handshake capability
AH1	Full acceptor handshake capability
T8	Basic talker. No serial poll. No talk only mode. Unaddressed if MLA.
L4	Basic listener. No listen only mode. Unaddressed if MTA
SR0	No service request capability
RL1	Complete remote/local capability
PP0	No parallel poll capability
DC1	Full device clear capability
DT0	No device trigger capability
E2	Tri-state driver electronics
C0	No controller capability

7. SERIAL PORT This port is used for the HP 83236B to be controlled by the HP 8924C whose firmware revision is A.05.00 and above or HP 8920B whose firmware revision is B.05.00 and above.

NOTE:

To enable this serial port, set the **HP-IB/Ser** switch of the HP-IB Address Selector to the “Ser” side (right side as viewed from the rear panel).

8. Power Cord Receptacle The PCS Interface can operate from AC sources of 90 to 132 Vac and 198 to 264 Vac (47 to 63 Hz). No internal changes are necessary to select AC supply.

Other Information

Power Requirements

The PCS Interface requires the following power source:

Voltage: 90 to 132 Vac, 198 to 264 Vac

Frequency: 47 to 63 Hz

Power: 100 VA maximum

Fuse

The main fuse is located inside of the PCS Interface. The type and rating of this fuse are as follows.

UL/CSA type, time delay, 3 A, 250 Vac

WARNING:

The main fuse is not replaceable by the operator. Refer servicing to qualified personnel.

Ventilation Requirements

To ensure adequate ventilation, make sure that there is adequate clearance around the PCS Interface.

Instructions for Cleaning

For cleaning, wipe lightly with a soft damp cloth.

Installation

Before attempting to make measurements or generate programs using the PCS Interface, it is a good idea to follow the steps in this chapter. This will ensure that the proper connections are made between the PCS Interface and other hardware and will verify basic operation of the Test System.

Introduction

Chapter Overview Included in this chapter are steps for setting up the PCS Interface for the following test configurations:

Table 8 PCS Interface Test Configurations

If you are testing...	And your Test Set Model is...	With Cellular Adapter Model...	You will control the PCS Interface using...	Refer to...
CDMA Subscriber Units	HP 8924C (Firmware: A.05.00 and above)	—	Serial Port	See page 34.
	HP 8924C (Firmware: Below A.05.00)	—	HP-IB	See Page 37.
TDMA Subscriber Units	HP 8920B (Firmware: B.05.00 and above)	HP 83206A	Serial Port	See page 40.
	HP 8920B (Firmware: Below B.05.00)	HP 83201A,B, HP 83206A	HP-IB	See page 45.
	HP 8920A	HP 83201A,B		
CDMA Base Stations	HP 8921A	HP 83203B, HP 83205A	HP-IB	See page 50.
TDMA Base Stations	HP 8921A	HP 83201A, HP 83204A		See page 54.

The PCS Interface can be controlled by the following methods.

- Serial Port Control

The HP 8920B option 800 with firmware revision B.05.00 and above and HP 8924C with firmware revision A.05.00 and above can control the PCS Interface via the serial port. Using this mode eliminates the need to control the PCS Interface independently.

- HP-IB Control

All of the above Test Sets can control the PCS Interface via the HP-IB. You can use the Manual Control Software or you can make programs to control the PCS Interface.

You will be shown how to set up the equipment, make connections, and run a software utility that verifies the connections and the instruments' operation.

NOTE:

When you want to use the PCS Interface with the HP 8924C on the work bench, the PCS Interface's Option 1AB Bench Top Kit is required to stack the HP 8924C on the PCS Interface.

When Used with HP 8924C and Controlled via Serial Port for CDMA Subscriber Unit Tests

NOTE:

To control the PCS Interface via the serial port, the firmware of the HP 8924C must be A.05.00 and above. Contact your nearest Hewlett-Packard sales office for firmware upgrade information.

Unpack the PCS Interface and Accessories

Follow these steps to prepare the Test System for setup:

- 1 Unpack the test equipment and accessories.

NOTE:

This product passed all applicable electrical and mechanical inspections before it was shipped from the factory. As soon as you receive it, check that it is not damaged and that all accessories are present (see table 2 on page 19). Should this product be damaged or any accessories be missing, contact your local HP sales office or the company from which you purchased it.

- 2 Mount the PCS Interface into the PCS Interface's option 1AB bench top kit.
- 3 Place the HP 8924C Test Set on the top of the PCS Interface.

Cable Connections Follow these steps to prepare the test equipment for use:

- 1 Set the HP-IB Address Selector of the rear panel of the PCS Interface as follows.

HP-IB/Ser switch	Ser
HP-IB address	Any

- 2 Make the front and rear panel connections shown in figure 5.
- 3 Turn on the PCS Interface.

NOTE:

The PCS Interface must be powered on and connected before the HP 8924C is powered on. If the PCS Interface is not powered on first, the HP 8924C will not detect it.

- 4 Set up the Test Set.
 - a Turn on the Test Set.
 - b Press and release the SHIFT key then the TESTS key to access the CONFIGURE screen.
 - c Position the cursor in the “PCS Intrfc Control” field, and press the knob to select “On.”
 - d Turn the Test Set’s power off and then back on.
- 5 Perform the RF Generator Level Calibration.
 - a Press and release the SHIFT key then the TESTS key to access the CONFIGURE screen.
 - b Position the cursor in the “RF Gen Level” field, and press the knob to start the calibration.

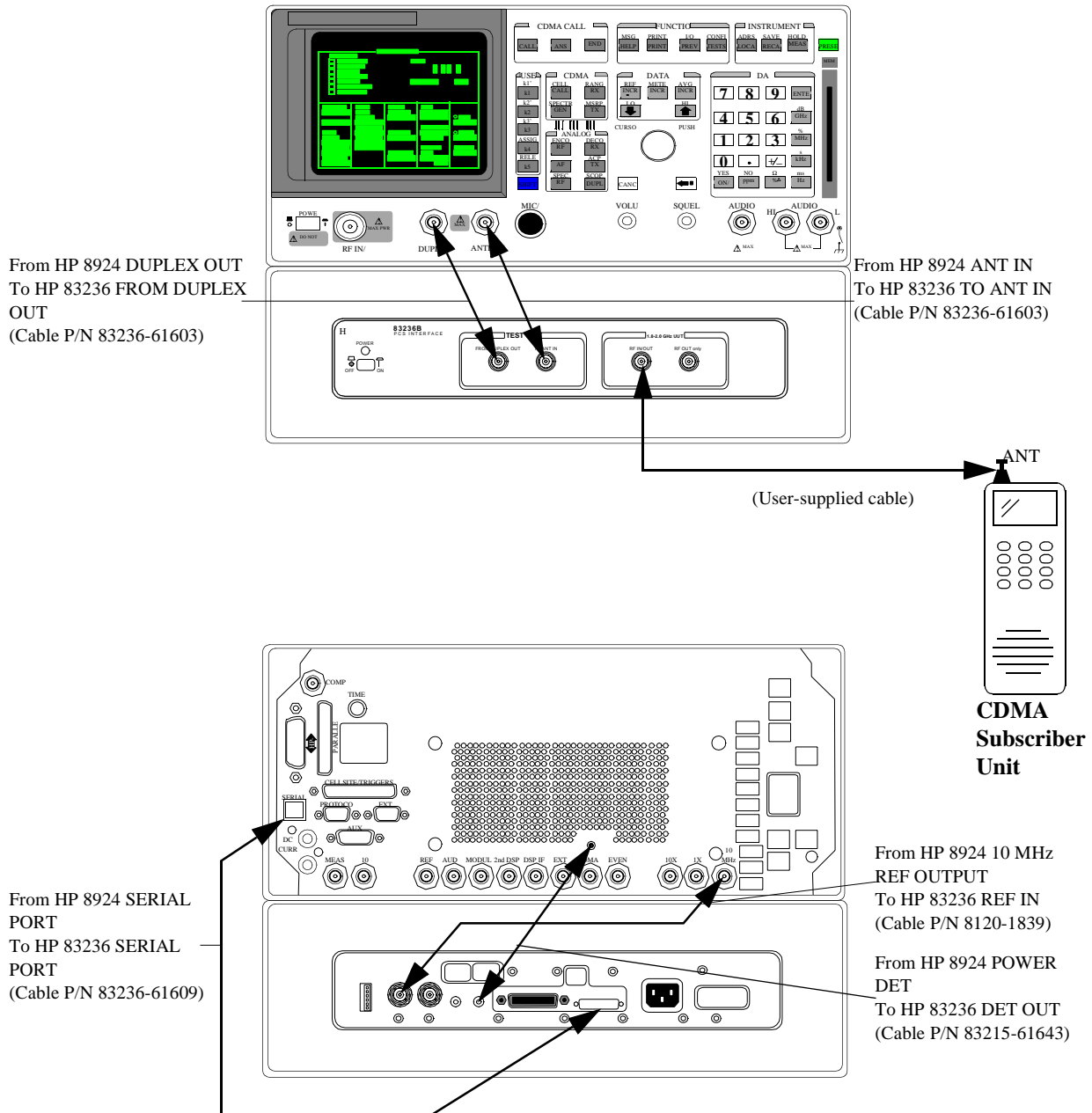

Figure 5 Connection diagrams for the HP 8924C Test Configuration (CDMA Subscriber Unit Tests; Serial Control)

When Used with HP 8924C and Controlled via HP-IB for CDMA Subscriber Unit Tests

Unpack the PCS Interface and Accessories

Follow these steps to prepare the Test System for setup:

- 1 Unpack the test equipment and accessories.

NOTE:

This product passed all applicable electrical and mechanical inspections before it was shipped from the factory. As soon as you receive it, check that it is not damaged and that all accessories are present (see table 2 on page 19). Should this product be damaged or any accessories be missing, contact your local HP sales office or the company from which you purchased it.

- 2 Mount the PCS Interface into the PCS Interface's option 1AB bench top kit.
- 3 Place the HP 8924C Test Set on the top of the PCS Interface.

Cable Connections Follow these steps to prepare the test equipment for use:

- 1 Set the HP-IB Address Selector on the rear panel of the PCS Interface as follows.

HP-IB/Ser switch HP-IB

HP-IB address 19 (for the manual control software and connectivity test)

- 2 Make the front and rear panel connections shown in figure 6.
- 3 Turn on the PCS Interface.
- 4 Turn on the Test Set.

NOTE:

Make sure that the “PCS Intrfc Control” field in the CONFIGURE screen is set to “Off.”
To access the CONFIGURE screen, press and release the SHIFT key then the TESTS key.

When Used with HP 8924C and Controlled via HP-IB for CDMA Subscriber Unit Tests

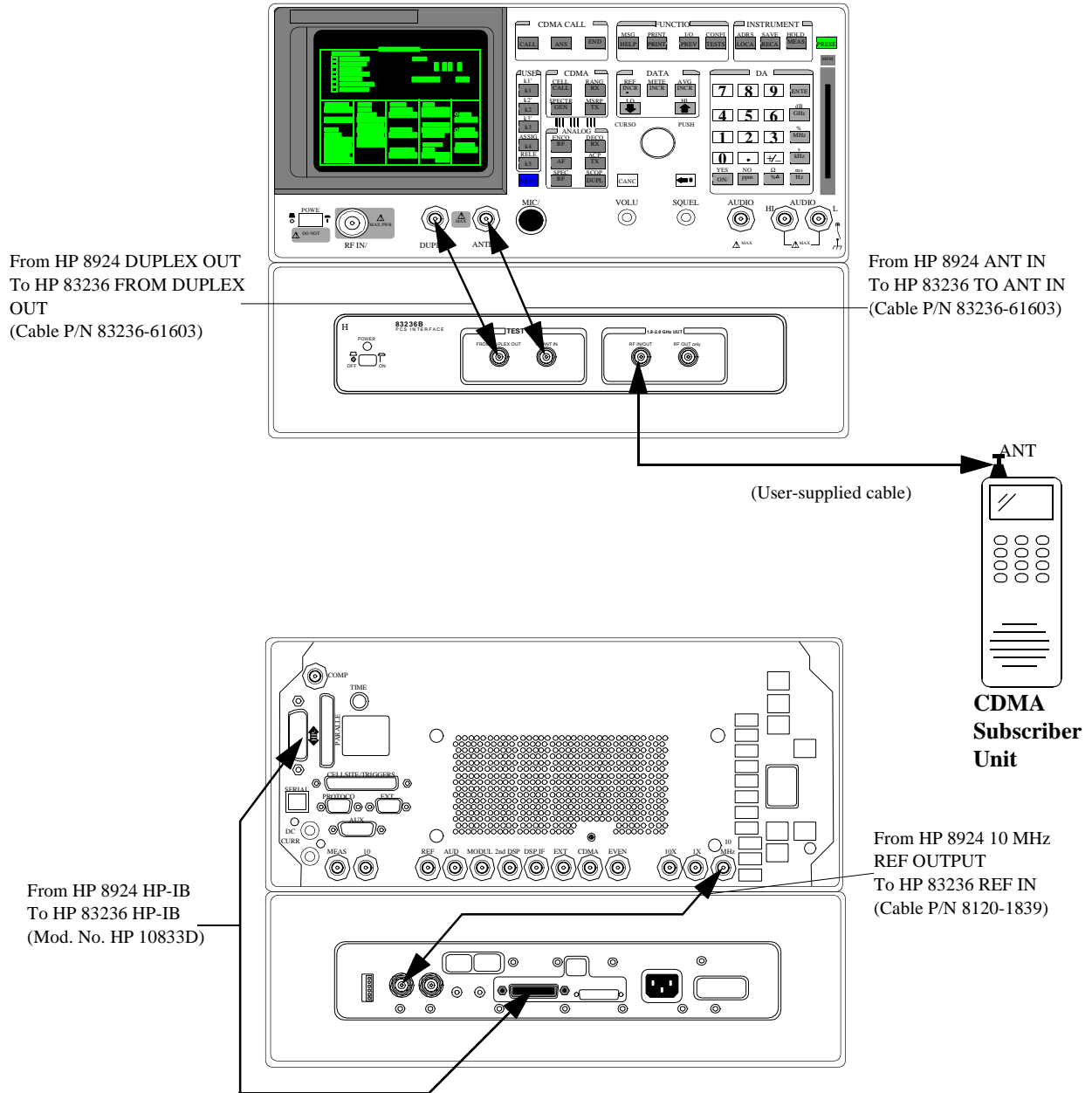

Figure 6 Connection diagrams for the HP 8924 Test Configuration (CDMA Subscriber Unit Tests; HP-IB Control)

When Used with HP 8920B and Controlled via Serial Port for TDMA Subscriber Unit Tests

NOTE:

To control the PCS Interface via the serial port, the firmware of the HP 8920B must be B.05.00 and above, and the HP 83206A must be used for the Test System's Cellular Adapter. Contact your nearest Hewlett-Packard sales office for firmware upgrade information.

Unpack the PCS Interface and Accessories

Follow these steps to prepare the Test System for setup:

- 1 Unpack the test equipment and accessories.

NOTE:

This product passed all applicable electrical and mechanical inspections before it was shipped from the factory. As soon as you receive it, check that it is not damaged and that all accessories are present (see table 2 on page 19). Should this product be damaged or any accessories be missing, contact your local HP sales office or the company from which you purchased it.

- 2 Placing the equipment:

- a If you are placing the Test System horizontally (on a bench top, for example) place the Test Set (together with the Cellular Adapter) on the top of the PCS Interface. Position the bumpers (feet) of the Test Set so that they are stably seated between the forward and rear bumpers of the PCS Interface. Refer to figure 7.

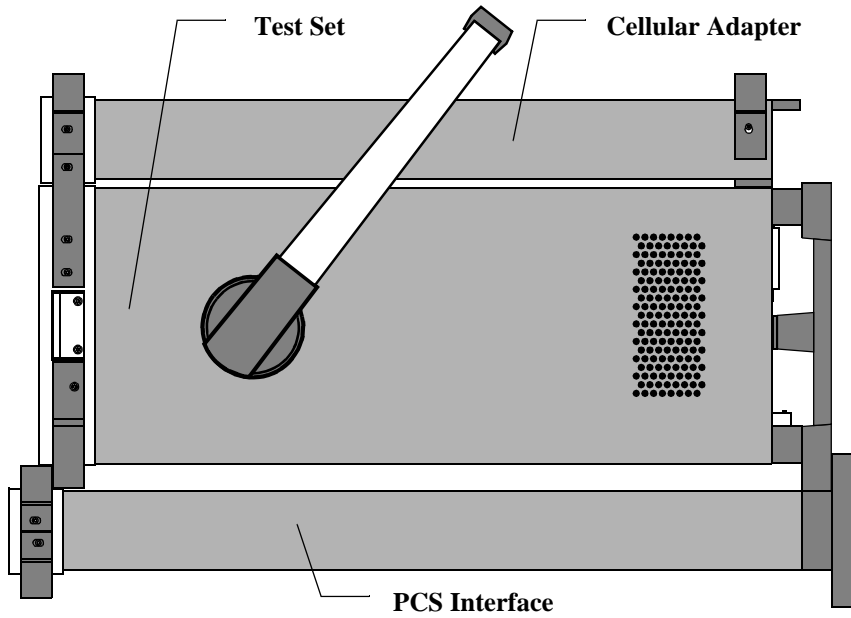

Figure 7 Horizontal stacking configuration (side view) for the HP 8920 Test Configuration

- b If you are placing the Test System vertically (as is often done when putting the equipment on the floor), the PCS Interface's rear feet must be placed on the same surface as those of the Test Set. After placement, rotate the handle of the Test Set downwards to provide support for the PCS Interface. Refer to figure 8.

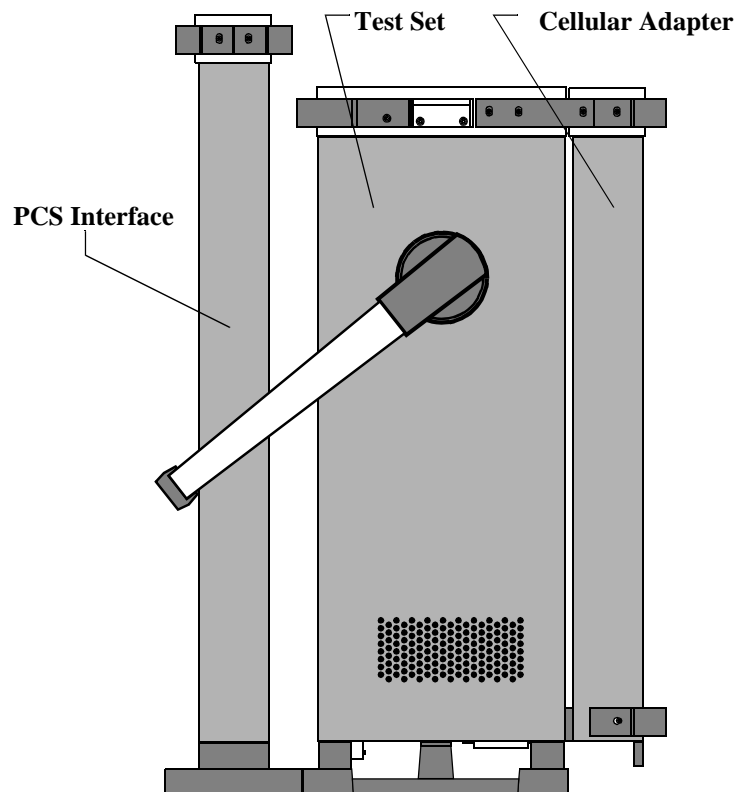

Figure 8

Vertical configuration (side view) for the HP 8920 Test Configuration

When Used with HP 8920B and Controlled via Serial Port for TDMA Subscriber Unit Tests

Cable Connections Follow these steps to prepare the test equipment for use:

NOTE:

You should have made all connections between the Test Set and Cellular Adapter at this point. Refer to the User's Guide for your particular Cellular Adapter for instructions on connecting it to the Test Set. Verify these connections before continuing with these steps.

- 1 Set the HP-IB Address Selector on the rear panel of the PCS Interface as follows.

HP-IB/Ser switch	Ser
HP-IB address	any

- 2 Make the front and rear panel connections shown in figure 9.
- 3 Turn on the PCS Interface.

NOTE:

The PCS Interface must be powered on and connected before the HP 8920B is powered on. If the PCS Interface is not powered on first, the HP 8920B will not detect it.

- 4 Turn on the Test Set.

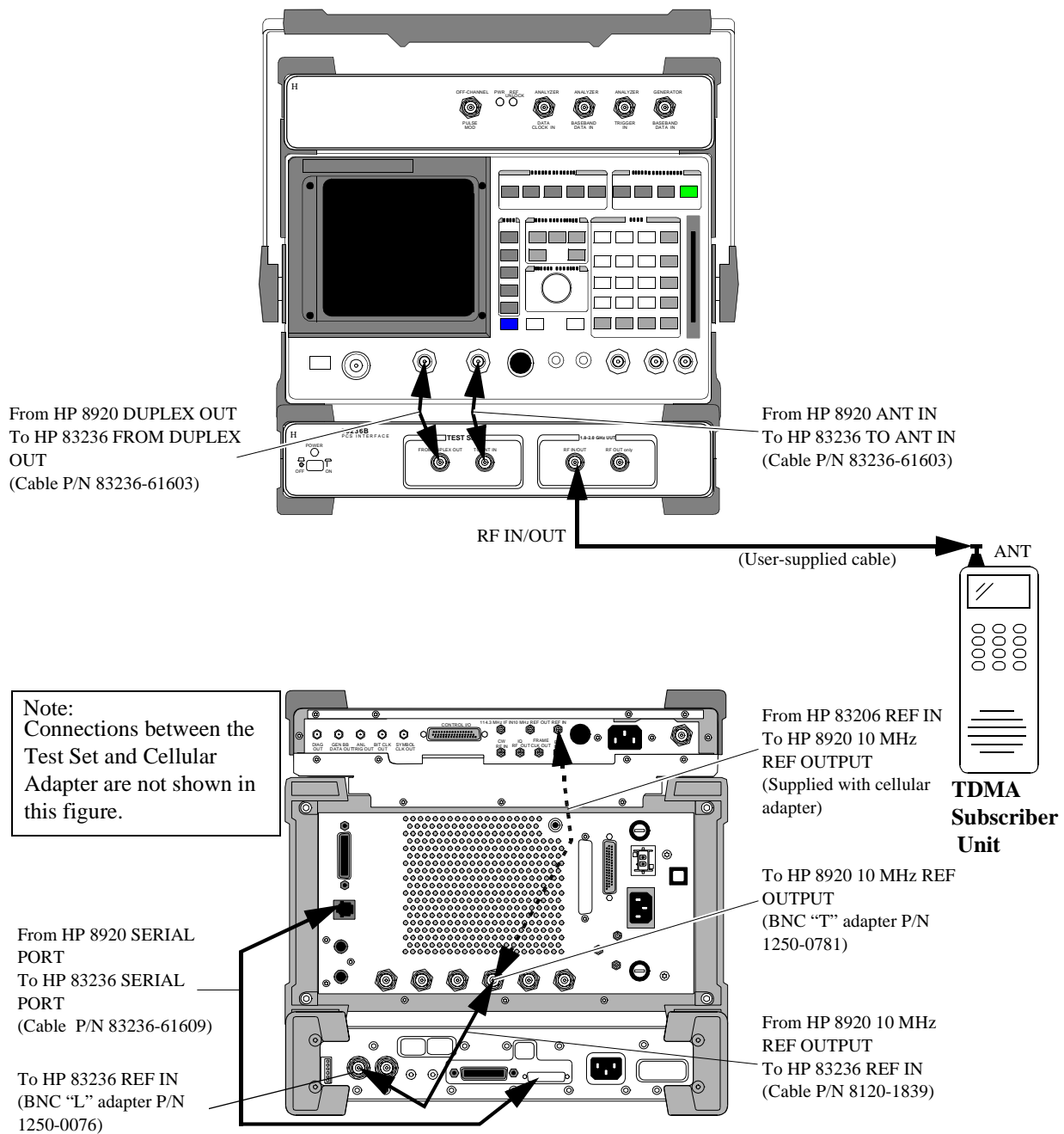

Figure 9 Connection diagrams for the HP 8920 Test Configuration (TDMA Subscriber Unit Tests; Serial Control)

When Used with HP 8920A,B and Controlled via HP-IB for TDMA Subscriber Unit Tests

Unpack the PCS Interface and Accessories

Follow these steps to prepare the Test System for setup:

- 1 Unpack the test equipment and accessories.

NOTE:

This product passed all applicable electrical and mechanical inspections before it was shipped from the factory. As soon as you receive it, check that it is not damaged and that all accessories are present (see table 2 on page 19). Should this product be damaged or any accessories be missing, contact your local HP sales office or the company from which you purchased it.

2 Placing the equipment:

- a If you are placing the Test System horizontally (on a bench top, for example) place the Test Set (together with the Cellular Adapter) on the top of the PCS Interface. Position the bumpers (feet) of the Test Set so that they are stably seated between the forward and rear bumpers of the PCS Interface. Refer to figure 10.

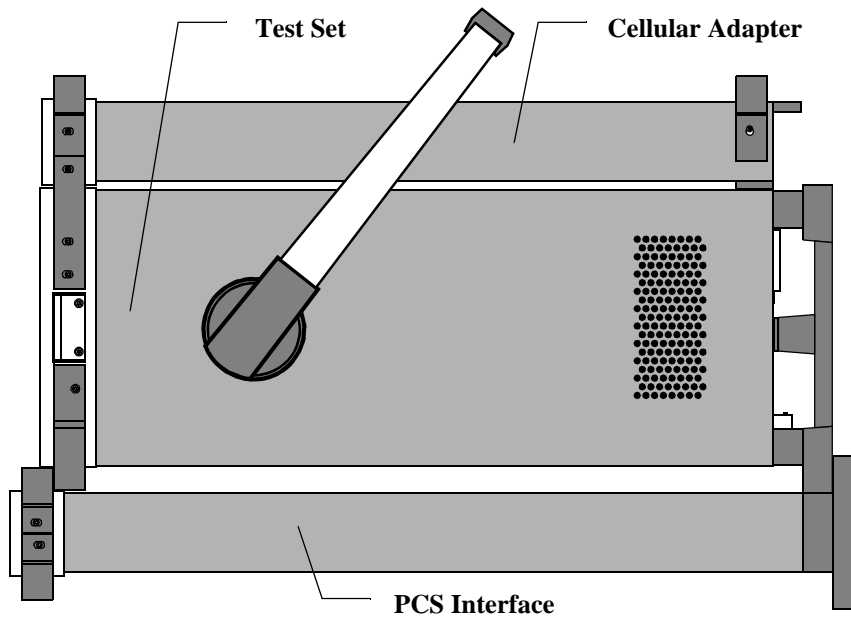

Figure 10

Horizontal stacking configuration (side view) for the HP 8920 or HP 8921 Test Configuration

- b If you are placing the Test System vertically (as is often done when putting the equipment on the floor), the PCS Interface's rear feet must be placed on the same surface as those of the Test Set. After placement, rotate the handle of the Test Set downwards to provide support for the PCS Interface. Refer to figure 11.

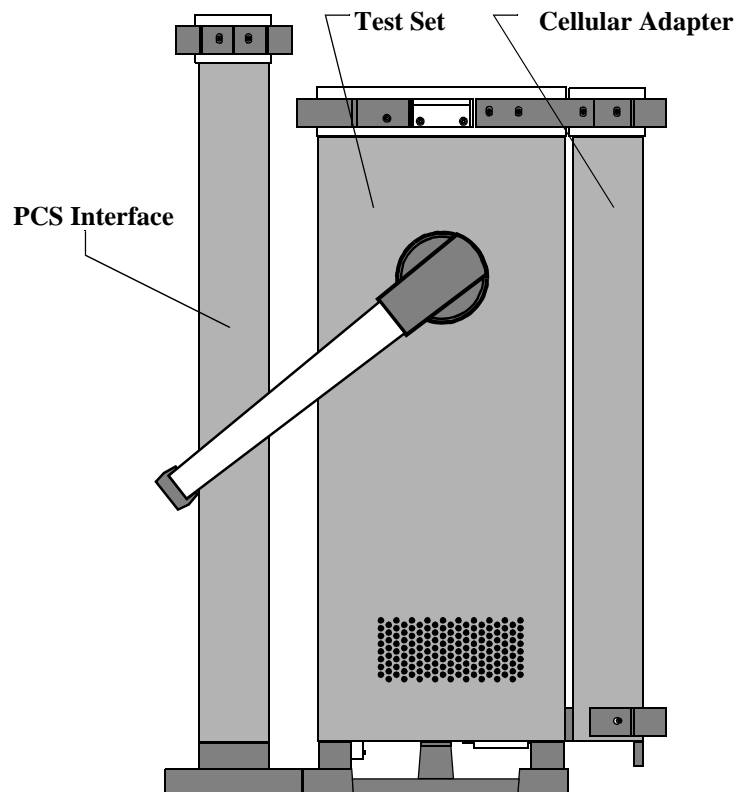

Figure 11

Vertical configuration (side view) for the HP 8920 or HP 8921 Test Configuration

Cable Connections Follow these steps to prepare the test equipment for use:

NOTE:

You should have made all connections between the Test Set and Cellular Adapter at this point. Refer to the User's Guide for your particular Cellular Adapter for instructions on connecting it to the Test Set. Verify these connections before continuing with these steps.

- 1 Set the HP-IB Address Selector on the rear panel of the PCS Interface as follows.

HP-IB/Ser switch

HP-IB

HP-IB address

19 (for the manual control software and connectivity test)

- 2 Make the front and rear panel connections shown in figure 12.

Consult the User's Guide for your Cellular Adapter for further details about using these timebase signals in your measurements.

- 3 Turn on the PCS Interface.

NOTE:

The PCS Interface must be powered on and connected before the HP 8920B is powered on. If the PCS Interface is not powered on first, the HP 8920A,B will not detect it.

- 4 Turn on the Test Set.

Chapter 2, Installation
 When Used with HP 8920A,B and Controlled via HP-IB for TDMA Subscriber Unit Tests

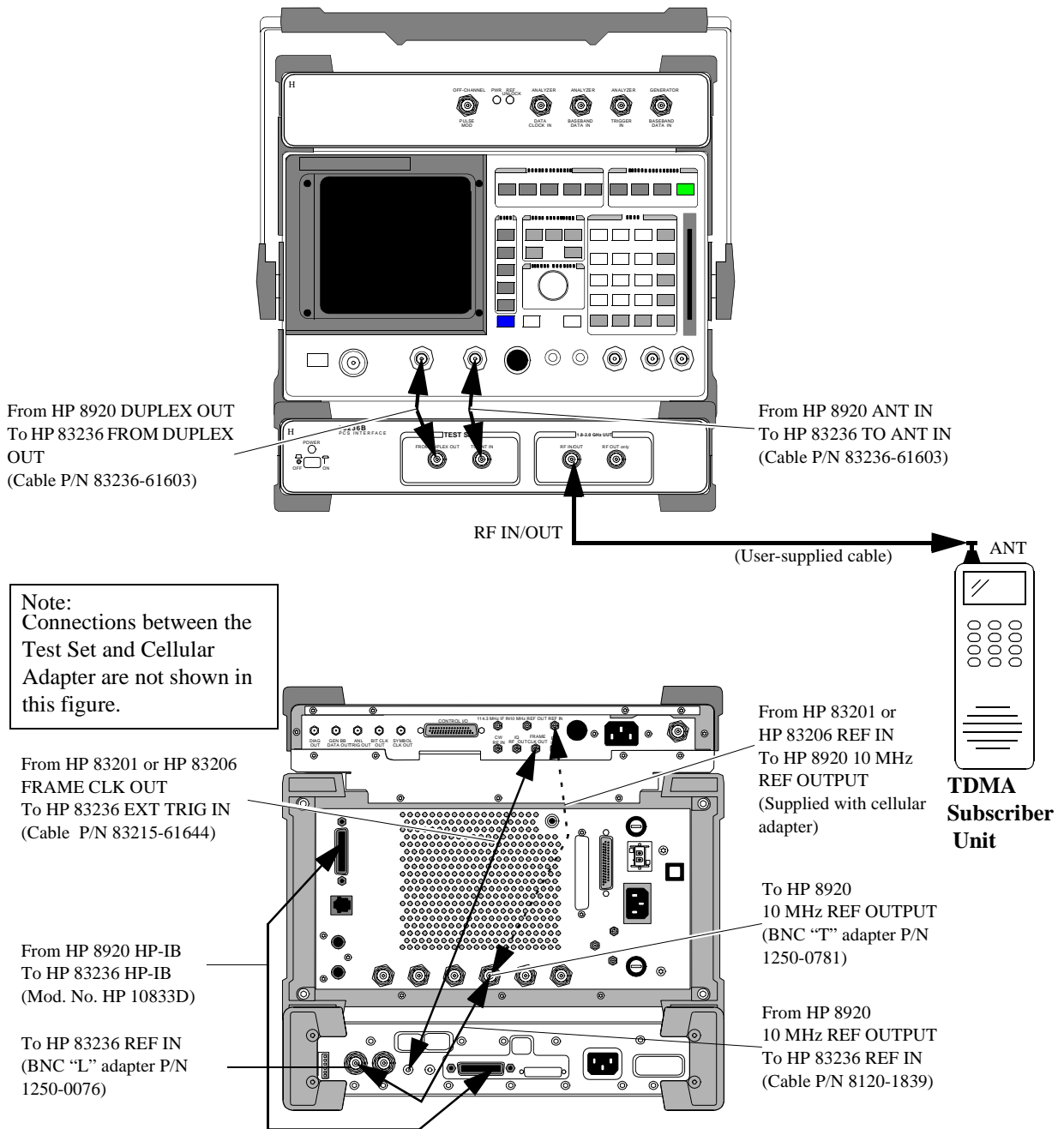

Figure 12 Connection diagrams for the HP 8920 Test Configuration (TDMA Subscriber Unit Tests; HP-IB Control)

When Used with HP 8921A for CDMA Base Stations Tests

Unpack the PCS Interface and Accessories

Follow these steps to prepare the Test System for setup:

- 1 Unpack the test equipment and accessories.

NOTE:

This product passed all applicable electrical and mechanical inspections before it was shipped from the factory. As soon as you receive it, check that it is not damaged and that all accessories are present (see table 2 on page 19). Should this product be damaged or any accessories be missing, contact your local HP sales office or the company from which you purchased it.

- 2 Placing the equipment:

- a If you are placing the Test System horizontally (on a bench top, for example) place the Test Set (together with the Cellular Adapter) on the top of the PCS Interface. Position the bumpers (feet) of the Test Set so that they are stably seated between the forward and rear bumpers of the PCS Interface. Refer to figure 10.

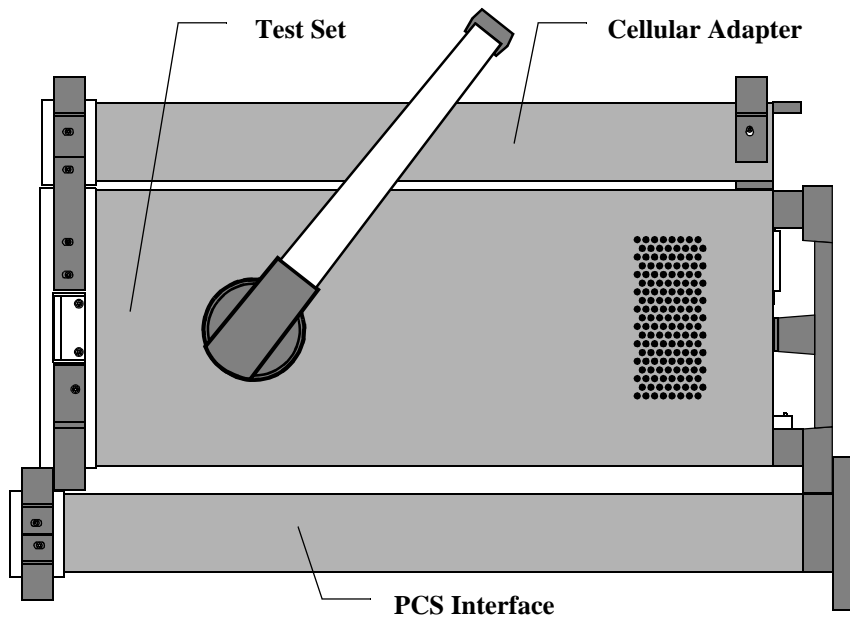

Figure 13 Horizontal stacking configuration (side view) for the HP 8921 Test Configuration

- b If you are placing the Test System vertically (as is often done when putting the equipment on the floor), the PCS Interface's rear feet must be placed on the same surface as those of the Test Set. After placement, rotate the handle of the Test Set downwards to provide support for the PCS Interface. Refer to figure 11.

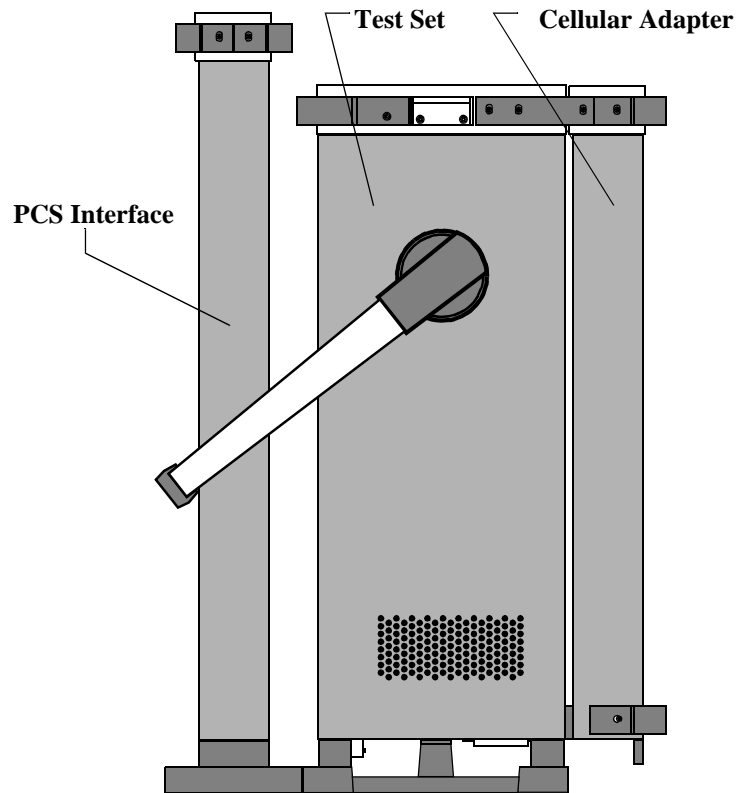

Figure 14

Vertical configuration (side view) for the HP 8921 Test Configuration

Cable Connections Follow these steps to prepare the test equipment for use:

NOTE:

You should have made all connections between the Test Set and Cellular Adapter at this point. Refer to the User's Guide for your particular Cellular Adapter for instructions on connecting it to the Test Set. Verify these connections before continuing with these steps.

- 1 Set the HP-IB Address Selector on the rear panel of the PCS Interface as follows.

HP-IB/Ser switch

HP-IB

HP-IB address

19 (for the manual control software and connectivity test)

- 2 Make the front and rear panel connections shown in figure 15.

Consult the User's Guide for your Cellular Adapter for further details about using these timebase signals in your measurements.

- 3 Turn on the PCS Interface.

NOTE:

The PCS Interface must be powered on and connected before the HP 8920B is powered on. If the PCS Interface is not powered on first, the HP 8921A will not detect it.

- 4 Turn on the Test Set.

Chapter 2, Installation
When Used with HP 8921A for CDMA Base Stations Tests

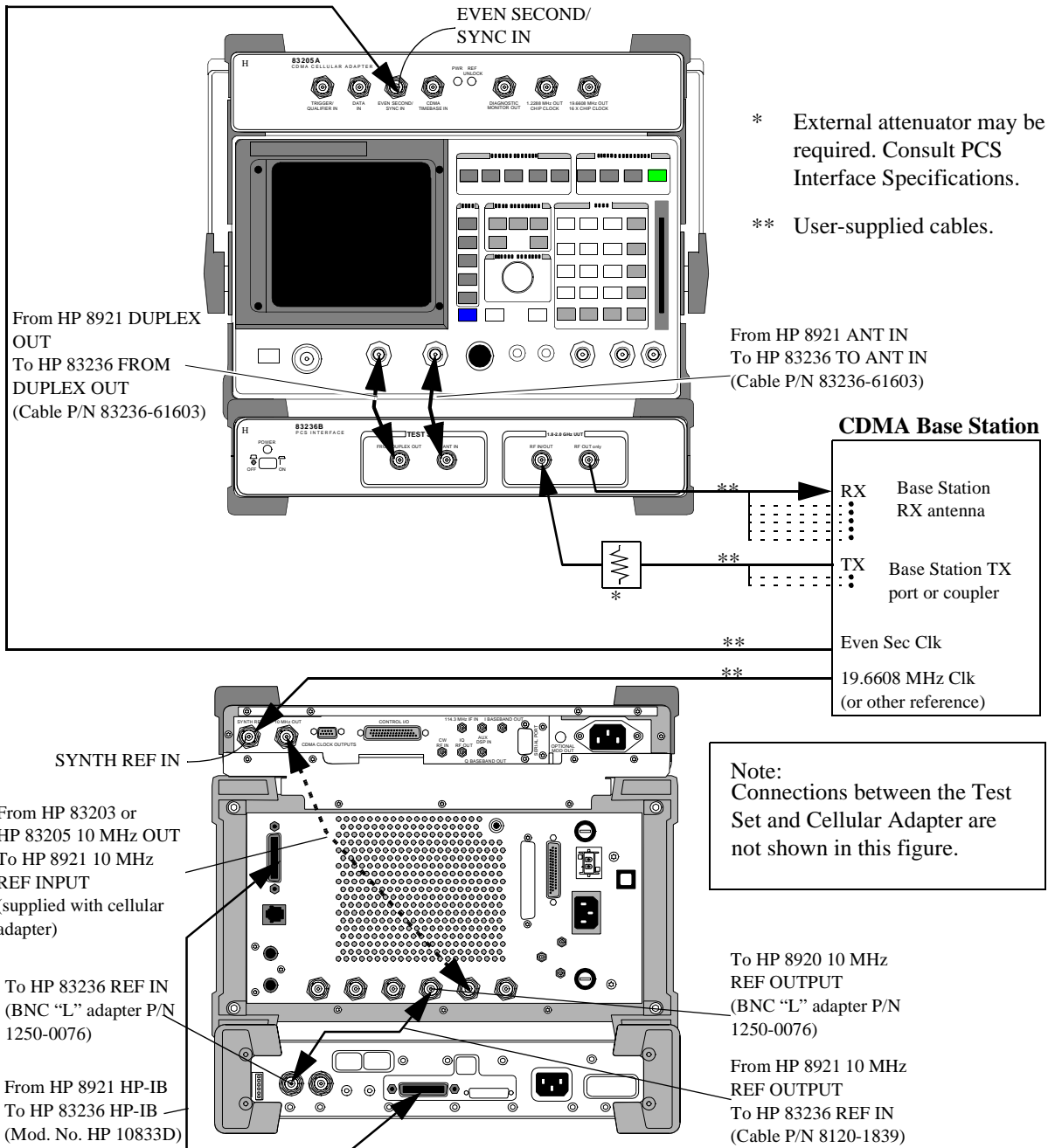

Figure 15 Connection Diagram for the HP 8921 Test Configuration (CDMA Base Station Tests)

When Used with HP 8921A for TDMA Base Stations Tests

Unpack the PCS Interface and Accessories

Follow these steps to prepare the Test System for setup:

- 1 Unpack the test equipment and accessories.

NOTE:

This product passed all applicable electrical and mechanical inspections before it was shipped from the factory. As soon as you receive it, check that it is not damaged and that all accessories are present (see table 2 on page 19). Should this product be damaged or any accessories be missing, contact your local HP sales office or the company from which you purchased it.

- 2 Placing the equipment:

- a If you are placing the Test System horizontally (on a bench top, for example) place the Test Set (together with the Cellular Adapter) on the top of the PCS Interface. Position the bumpers (feet) of the Test Set so that they are stably seated between the forward and rear bumpers of the PCS Interface. Refer to figure 10.

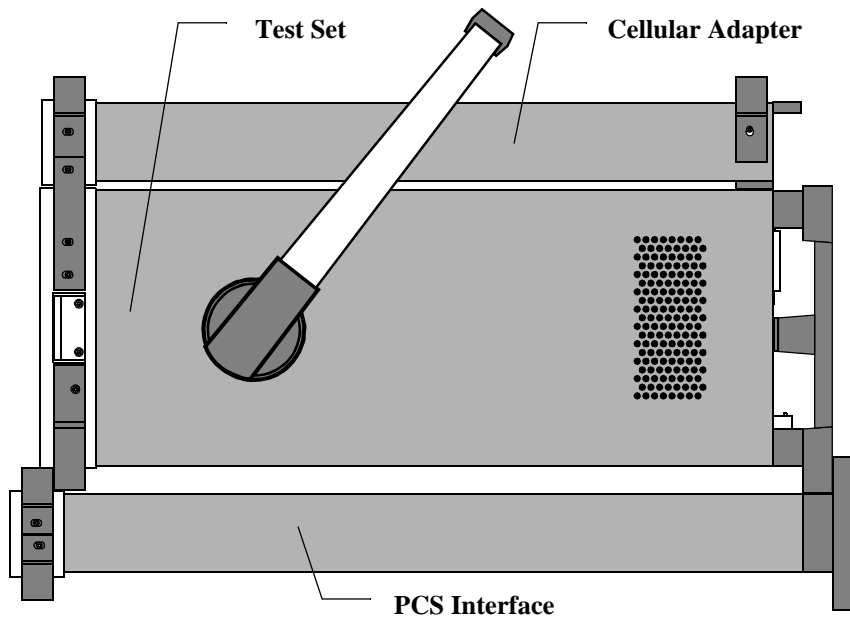

Figure 16 Horizontal stacking configuration (side view) for the HP 8921 Test Configuration

- b If you are placing the Test System vertically (as is often done when putting the equipment on the floor), the PCS Interface's rear feet must be placed on the same surface as those of the Test Set. After placement, rotate the handle of the Test Set downwards to provide support for the PCS Interface. Refer to figure 11.

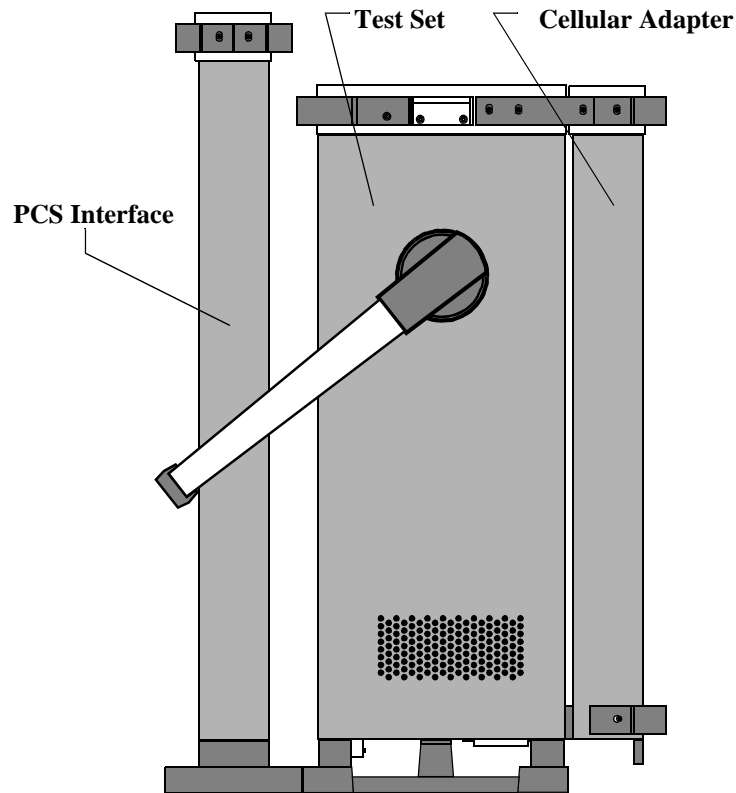

Figure 17

Vertical configuration (side view) for the HP 8921 Test Configuration

Cable Connections Follow these steps to prepare the test equipment for use:

NOTE:

You should have made all connections between the Test Set and Cellular Adapter at this point. Refer to the User's Guide for your particular Cellular Adapter for instructions on connecting it to the Test Set. Verify these connections before continuing with these steps.

- 1 Set the HP-IB Address Selector on the rear panel of the PCS Interface as follows.

HP-IB/Ser switch	HP-IB
HP-IB address	19 (for the manual control software and connectivity test)

- 2 Make the front and rear panel connections based on your UUT type:

- TDMA base station with frame clock: See figure 18.
- TDMA base station without frame clock: See figure 19.

Consult the User's Guide for your Cellular Adapter for further details about using these timebase signals in your measurements.

- 3 Turn on the PCS Interface.

NOTE:

The PCS Interface must be powered on and connected before the HP 8920B is powered on. If the PCS Interface is not powered on first, the HP 8921A will not detect it.

- 4 Turn on the Test Set.

Chapter 2, Installation
 When Used with HP 8921A for TDMA Base Stations Tests

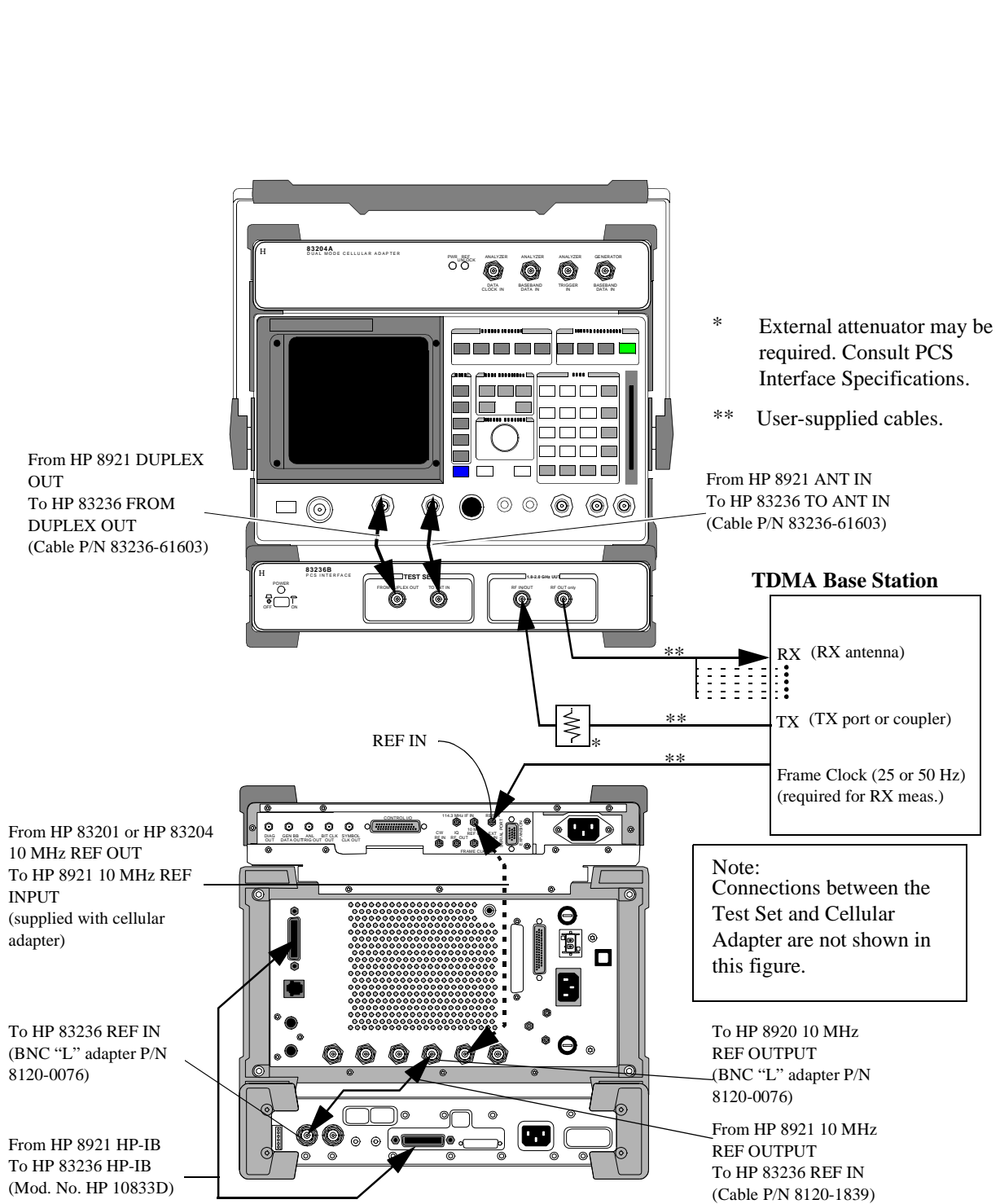

Figure 18 Connection Diagram for the HP 8921 Test Configuration (TDMA Base Station Tests with Frame Clock)

Chapter 2, Installation
 When Used with HP 8921A for TDMA Base Stations Tests

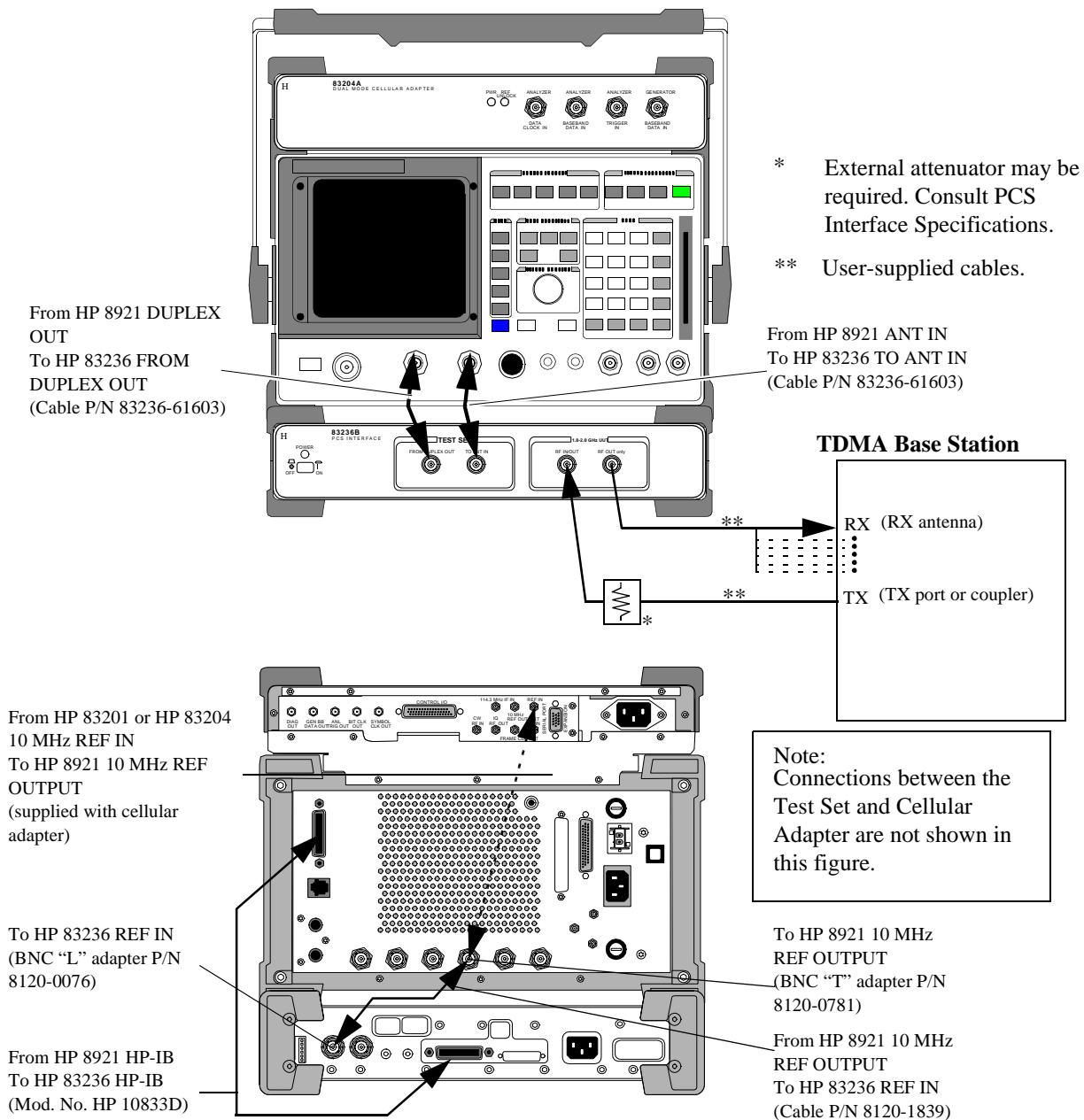

Figure 19 Connection Diagram for the HP 8921 Test Configuration (TDMA Base Station Tests with Frame Clock)

Load and Run the Connectivity Test Software (Option 001 or 002)

The connectivity test is used to verify that the connections between the test equipment are correct and that the cables are intact. The software also performs basic functionality checks of each instrument in the Test System.

NOTE:

The connectivity test is supplied on the memory card shipped with the HP 83236B option 001, utility software on PCMCIA card, or option 002, utility software on EPSON memory card. Use the PCMCIA card for the HP 8924C or HP 8920B; use the EPSON memory card for the HP 8920A or HP 8921A.

- 1 Make proper connections between the Test Set and the PCS Interface.
- 2 When the PCS Interface is controlled via HP-IB Interface, set the HP-IB address to 19 on the rear panel of the PCS Interface.
- 3 When you are testing base stations, make front and rear panel connections shown in figure 20.
- 4 To prepare the Test Set for running the connectivity test, perform the steps shown in figure 21.
- 5 To load and run the software, follow the steps of figure 22.

NOTE:

Use the N(f)-BNC(m) and the N(m)-BNC(f) adapters shipped with the HP 83236B options 001 and 002 when they are required to connect the cables.

Chapter 2, Installation
Load and Run the Connectivity Test Software (Option 001 or 002)

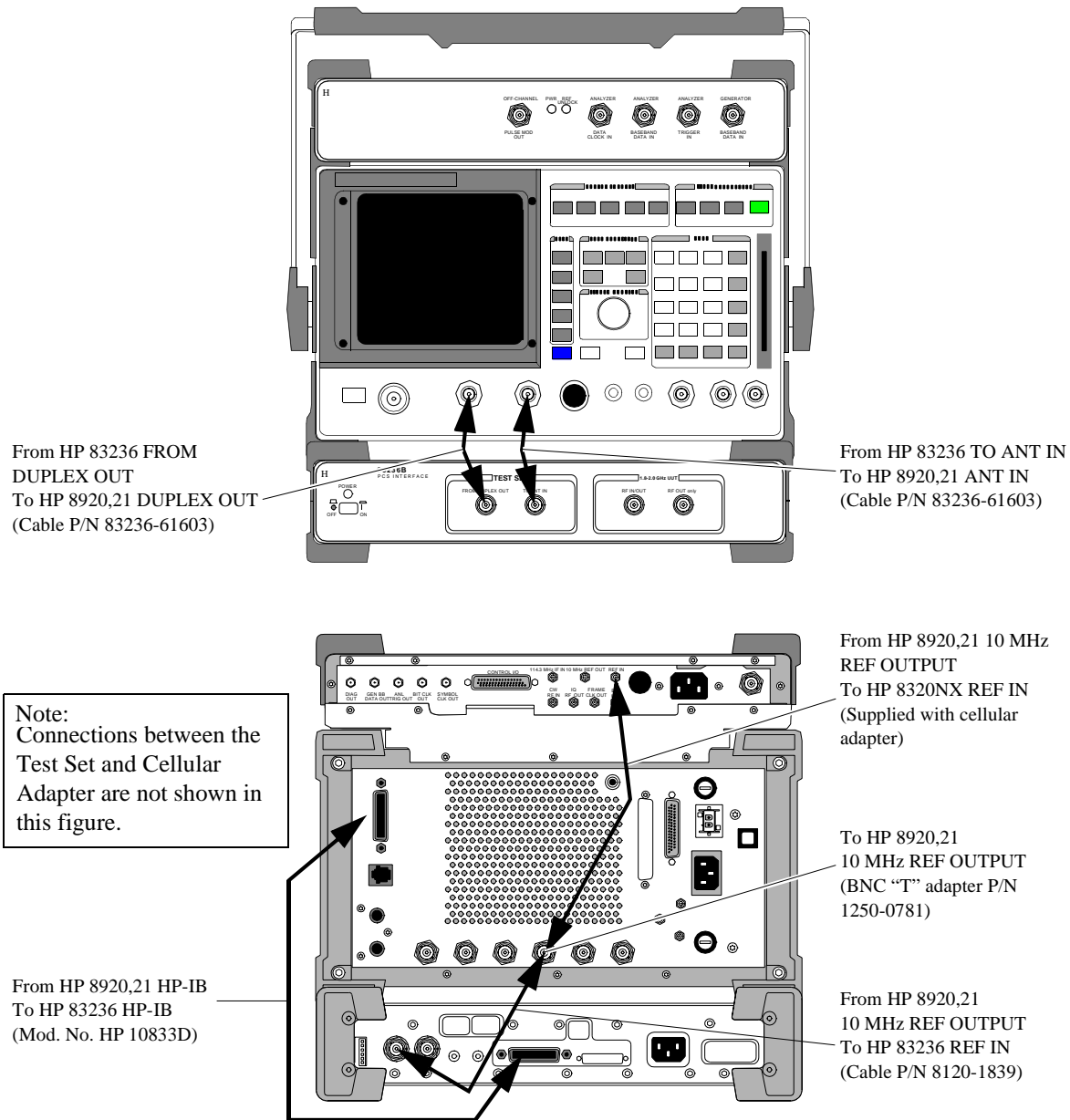

Figure 20 Connectivity Test Connection diagrams for the Base Station Test Configuration

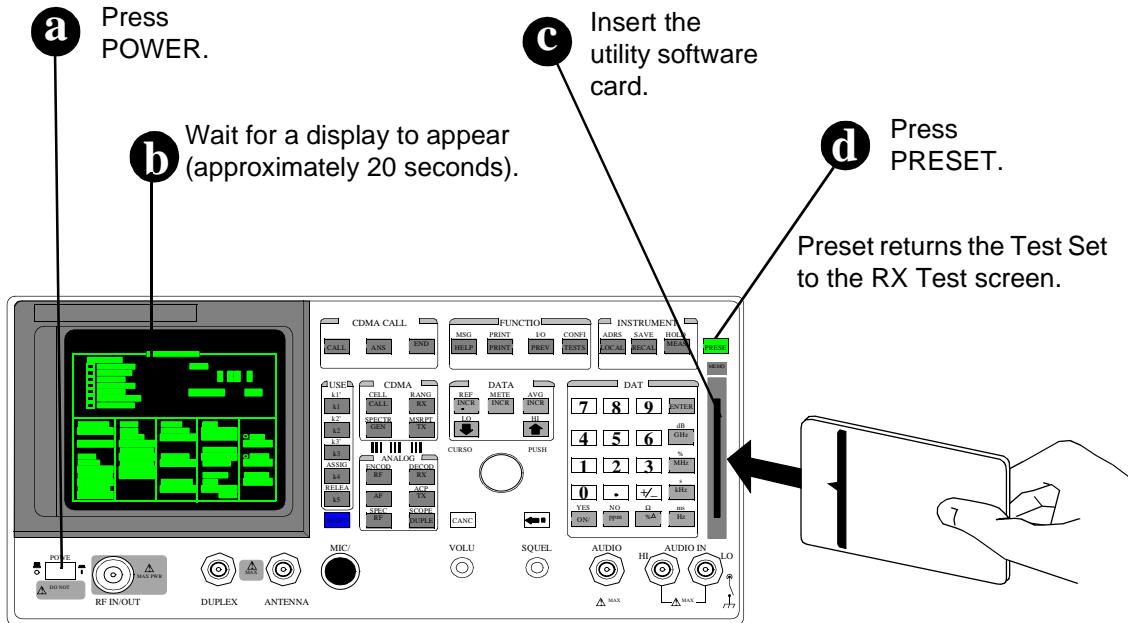

Figure 21 Turning power on and inserting the memory card.







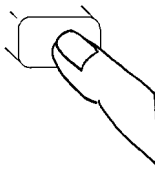

<p>1 Press TESTS to display the TESTS (Main Menu) screen.</p> <p>If you are in the IBASIC TESTs screen press, PRESET before pressing TESTS.</p> 	<p>2 Position cursor at Select Procedure Location: and select it.</p> <p>Position</p>  <pre>LOAD TEST PROCEDURE: Select Procedure Location: █ Select Procedure Filename: █</pre> <p>Select</p> 
<p>3 Position cursor at Card and select it.</p> <p>Position</p>  <pre>Choices: █ Card ROM RAM Disk</pre> <p>Select</p> 	<p>4 Position cursor at Select Procedure Filename: and select it.</p> <p>Position</p>  <pre>LOAD TEST PROCEDURE: Select Procedure Location: Card Select Procedure Filename: █</pre> <p>Select</p> 
<p>5 Position cursor at Choices: and select SYS_CONN.</p> <p>Position</p>  <pre>Choices: █ SYS_CONN</pre> <p>Select</p> 	<p>6 Position cursor at Run Test and select it. The software is now loading.</p> <p>Position</p>  <pre>1 Run Test 2 Continue 4 Help</pre> <p>Select</p>  <p>  Loading Time: First time: approximately 1.5 minutes. After first time: approximately 10 seconds. </p>

Figure 22 Loading and Running the Connectivity Test

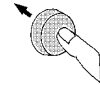
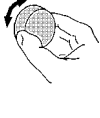
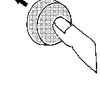
Notes about HP-IB connections Disconnect other HP-IB devices, *especially system controllers*, from the Test System before running the connectivity test. The Test Set is the system controller when the connectivity test is running and another (external) controller on the bus will generate a bus conflict error.

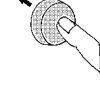
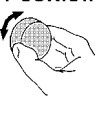
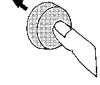
Connectivity Test guidelines The following general guidelines may be useful to you when running the connectivity test.

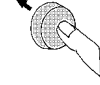
Presentation of results on the Test Set's display

The software uses the following conventions when displaying information on the Test Set's display:

Top display line: the very first line of text at the top of the Test Set display is used to indicate the test being performed.

Two-line inverse text area: just below the top display line is a two-line inverse video area that is used to prompt the user with instructions.

Main display area: below the inverse area is the main display area of the Test Set. This large area is used to display test results and to present error messages that may occur.

Softkey (USER key) label area: at the upper right of the Test Set's display are five inverse video labels that are used to indicate the function of the corresponding softkey (k1 - k5). These keys are used to run the software, continue it at key points, and for other assorted functions.

Pauses during connectivity test execution

As the testing is done to verify connectivity, the software will display abbreviated results on the main screen of the Test Set's display. If the program pauses and gives a prompt before the testing is complete, it is typically to communicate that it has found a problem. In this case the program will suggest cable paths (and cables) to check before going on with the testing.

Where to go next

If you have run the connectivity software with a pass result

Now that the Test System's operation has been verified, you will want to start making tests on radio equipment.

- If you are planning to test CDMA subscriber units using the HP 8924C with the serial port control, refer to the *HP 8924C User's Guide*.
- If you are planning to test TDMA subscriber units using the HP 8920B with the serial port control, refer to the *HP 8920B User's Guide*.
- If you are planning to test CDMA base stations using the HP 8921A, refer to the *CDMA/PCS Base Station Test Software User's Guide*.
- If you are planning to test radio equipment using the HP 8920A,B, HP 8921A, or HP 8924C with the HP-IB interface control, refer to the *Manual Control Software User's Guide* for the next steps in making tests using the manual control software.

If you encountered failures when running the connectivity software

If it finds problems, the connectivity software will prompt you to check various connections in the Test System. The software will then repeat the testing to verify that the problem has been corrected.

If failures persist after running the Test System connectivity software, you may have a failure in one of the pieces of test equipment in the Test System. The connectivity software will attempt to identify the failed unit. Once the suspected failed unit is identified, contact your nearest Hewlett-Packard Service Center for instructions on servicing the unit.

In North America you may call, toll-free, 1-800-827-3848 (between 9 am and 5 pm, Pacific time) for instructions on further troubleshooting and how to proceed if repairs are needed. Refer to the last page of this manual for service center addresses and locations.

Programming the PCS Interface using HP-IB Control

What's included in this chapter:

- Introduction
- Overview of programming issues
- PCS Interface programming guide

Introduction

The PCS Interface extends the frequency range of the Test Set to the 1710 to 1785 MHz, 1805 to 1910 MHz, and 1930 to 1990 MHz PCS band. Since the PCS Interface has no front-panel user controls, its only available control interface is through HP-IB.

NOTE:

To control the PCS Interface over HP-IB, some form of control software must be used. The software can run on either an external controller or in the Test Set's IBASIC controller. No "manual" front panel controls of the PCS Interface are provided.

The information in this chapter does *not* apply when an HP 8924C is controlling the PCS Interface over the serial port.

Purpose

This chapter is designed to assist Software Application Designers who will be integrating the PCS Interface into their own testing system and who as a result, will need to develop their own software. It provides task flow diagrams, programming examples, and recommends a testing theory to help guide the development of control software.

When integrating the PCS Interface into a custom test system, there are a few topics which must be considered. The following discussions provide general overviews of these topics. The remaining sections of this chapter then provide more specific procedures for making the various settings and measurements with the PCS Interface.

Overview of Programming Issues

Features

The basic features of the PCS Interface include:

- A PCS frequency RF generator for receiver testing
- A PCS frequency signal analyzer for transmitter testing
- A power detector for direct power measurements
- A temperature sensor for accuracy compensations

The PCS Interface takes the signal generated by the Test Set (810 to 995 MHz) at its FROM DUPLEX OUT port and upconverts it to a PCS frequency band (1710 to 1785 MHz, 1805 to 1910 MHz, or 1930 to 1990 MHz) signal at the unit-under-test (UUT) port.

Conversely, the PCS Interface takes the UUT's transmitted signal (1710 to 1785 MHz, 1805 to 1910 MHz, or 1910 to 1990 MHz), downconverts it to a frequency the Test Set is capable of analyzing (650 to 940 MHz), and applies it to the Test Set's ANT IN port. Both the PCS Interface's generator and analyzer paths include variable attenuators for controlling signal levels in the Test System.

The power detector inside the PCS Interface provides direct measurements of the UUT's transmitter power.

In order to provide the best possible accuracy and confidence in measurements, the PCS Interface has built-in temperature sensing circuitry which is used to determine whether re-calibration is needed. Three compensations are available for re-calibration and will be discussed in detail later in this chapter.

System Connections

NOTE:

It is assumed that all connections between the Test Set and Cellular Adapter have been made. Refer to the *User's Guide* for your Cellular Adapter for instructions on connecting it to the Test Set.

For connections between the Test Set and PCS Interface, refer to chapter 2, "Installation".

UUT Port Selection The PCS Interface has two ports available for UUT connection; the RF IN/OUT port and the RF OUT only port. Use the PCS Interface's RF IN/OUT port for single-port devices (for example, a subscriber unit) or its RF OUT only port for devices with separate RX and TX ports (for example, a base station).

Frequency Setting The PCS Interface provides a PCS frequency generator by upconverting the Test Set's generator signal with a stepped local oscillator (LO) and mixer. It down-converts a PCS frequency transmitter signal for analysis by the Test Set using a fixed frequency LO and mixer. For convenience, conversion bypass paths are also provided which eliminate any connection changes when testing devices in the 800 to 960 MHz band.

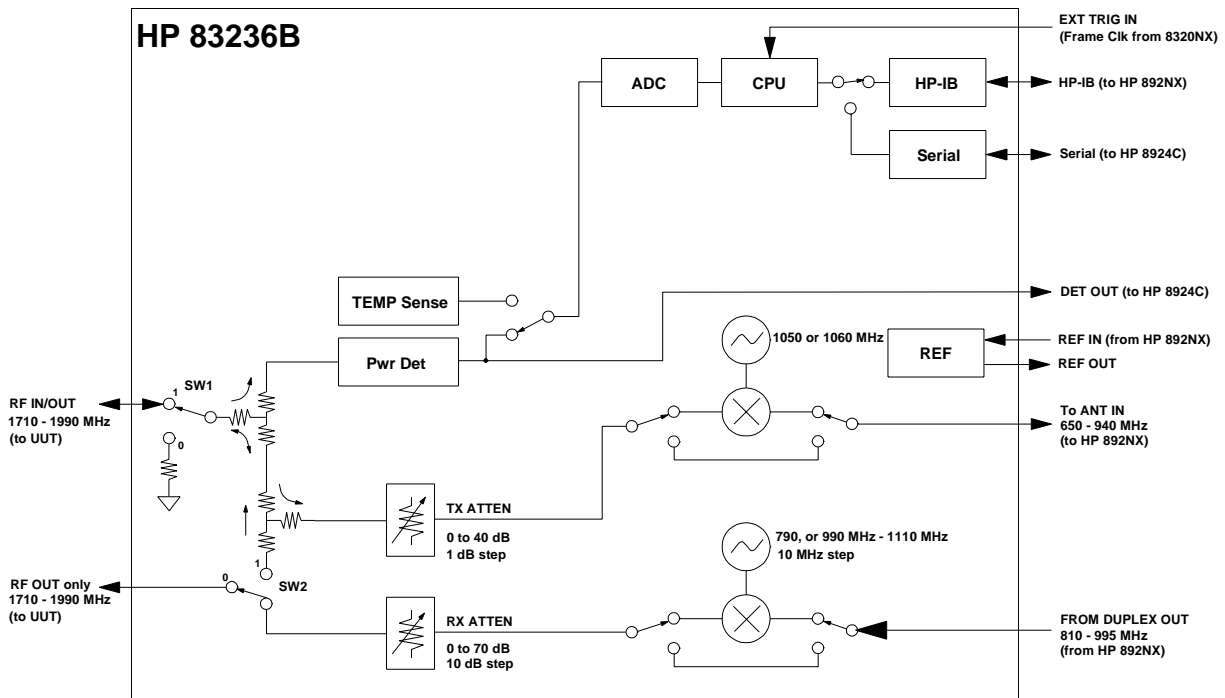

Figure 23 PCS Interface block diagram

NOTE:

The frequency conversion tables, used internally by the PCS Interface's CPU to determine the Test Set's frequencies, are shown in Appendix A, Frequency Conversion Tables on page 137.

The frequencies desired at the UUT's ports are set using HP-IB commands. When the PCS Interface receives the generator or analyzer frequency settings over HP-IB, its CPU automatically controls the conversion/bypass and internal LO settings in its generator and analyzer paths. In addition, the PCS Interface's CPU determines the frequencies required for the Test Set's RF generator and analyzer. These values are returned over HP-IB and are then used by the controlling software to set the Test Set's generator and analyzer frequencies.

**Generator level
Setting**

The PCS Interface's generator path has a 0 to 70 dB attenuator with 10 dB steps which provide coarse level settings of the RF generator. Fine level control is provided by the 0.1 dB resolution of the Test Set's DUPLEX OUT port.

The output signal level desired at the UUT's port is set using an HP-IB command. When the PCS Interface's generator level setting is received over HP-IB, the CPU of the PCS Interface automatically determines the appropriate generator path attenuator setting, and computes a level which should be set at the Test Set's DUPLEX OUT port. This level is returned over HP-IB and is then used by the controlling software to set the Test Set's RF generator level.

The automatic attenuator and level computations performed by the PCS Interface's CPU include two factors which are stored internally; a temperature (of the PCS Interface) factor and an attenuation step accuracy factor. The temperature correction factor is updated during the generator level temperature compensation which is discussed later. The attenuator step accuracy correction factor is established as part of the factory calibration. Both factors are also a function of the current generator frequency. Therefore, the generator level setting should be done *after* setting the desired RF generator frequency.

**Analyzer
Attenuator Setting**

The PCS Interface's analyzer path has a 0 to 40 dB attenuator with 1 dB steps. This attenuator is adjusted to optimize the signal level through the PCS Interface's downconverter to the Test Set's ANT IN port.

After the UUT's transmitter signal is applied to the PCS Interface's RF IN/OUT port, the setting of the analyzer path attenuator can be automatically set using an HP-IB command. When the command is received, the PCS Interface uses the internal peak detector to measure the peak power at its RF IN/OUT port, then computes and sets the analyzer path attenuator accordingly.

NOTE:

This is a one-time setting and does not place the PCS Interface in an auto-ranging mode. If the TX signal level changes, the attenuation setting command should be sent again.

The automatic computation performed by the PCS Interface's CPU to set the attenuator uses a factor stored in the PCS Interface; the attenuation step accuracy factor. The attenuator step accuracy correction factor is established as part of the factory calibration. This factor is also a function of the current analyzer frequency, therefore the automatic attenuator setting should be done after the UUT's transmitter frequency is set in the PCS Interface and after the UUT's transmitter signal is applied to the RF IN/OUT port.

NOTE:

The analyzer path attenuator can also be set to a specified value over HP-IB.

Power Detector, Triggering Types, and Power Measurements

The power detector

The PCS Interface has a built-in detector for direct power measurements of the UUT's transmitter signals connected to the RF IN/OUT port.

Triggering types

Trigger and data collection features have been included to provide direct power measurements of continuous wave (CW), TDMA, and continuous CDMA signals. Three triggering types are available.

- Immediate trigger
- Internal amplitude trigger
- External trigger

Detailed procedures for setting trigger types and data collection conditions are discussed later in this chapter.

Power measurements

After the UUT's transmitter signal is applied to the RF IN/OUT port and the desired trigger and data collection conditions are set in the PCS Interface, the power measurement is performed using an HP-IB query. When the query command is received, the PCS Interface's CPU collects power measurement samples from the internal detector, selects the appropriate data, calculates the resulting power, then returns the result over HP-IB.

The power calculation performed by the PCS Interface's CPU includes two correction factors, frequency drift and dc drift correction factors which are established during factory calibration. To assure that the correct factors are applied, the desired UUT transmitter frequency should be set in the PCS Interface and the dc offset compensation should be performed *before* making the power measurement.

Temperature Compensations

Power measurement accuracy and signal level accuracy in the PCS Interface are affected by temperature. The PCS Interface has an internal temperature sensor which is used during compensations which are necessary to ensure that the accuracy specified is achieved. Temperature compensations, which use a temperature sensor in the PCS Interface, are used to re-calibrate the PCS Interface when the temperature variations exceed an acceptable value. Default temperature changes are 1°C. This default value is required to maintain the performance specifications shown in chapter 5, "Specifications".

The two compensations

1. DC offset temperature compensation

This compensation procedure removes the dc drift of the power detector to provide accurate power measurements of signal levels less than 0 dBm. During this procedure the UUT connected to the PCS Interface's RF IN/OUT port is disconnected from the analyzer path so the zero power condition can be measured. This process updates the dc drift compensation factor used in power measurements.

Before making a transmitter power measurement, the dc offset temperature compensation should be performed using a single HP-IB command.

Since the UUT is internally disconnected from the Test Set during dc offset compensation, it should be performed before an active traffic/voice channel link is established if over-the-air protocol is used. Otherwise, the active call may be dropped.

NOTE:

Over-the-air protocol - The Test Set can essentially simulate a cellular base station and use over-the-air protocol to establish and maintain an active voice/traffic channel. This protocol can be used with a subscriber unit UUT connected to the Test System.

2. Generator level temperature compensation

This compensation is necessary to maintain the generator's output level accuracy which is used for testing receivers. During this procedure the UUT is automatically internally disconnected from the generator and analyzer path. The PCS Interface's internal compensation factors are used to compute the generator path attenuator values and the required signal level from the Test Set's DUPLEX OUT port.

Before using the generator for receiver testing, the need for a new generator level temperature compensation should be checked. The controlling software queries the PCS Interface to determine if a temperature compensation is necessary. If the compensation is necessary, it is performed by the controlling software with a few HP-IB commands.

Since the UUT is internally disconnected from the Test Set during generator level compensation, it should be performed before an active traffic/voice channel link is established if over-the-air protocol is used. Otherwise, the active call may be dropped.

NOTE:

Turn on desired modulation before the generator level temperature compensation for best accuracy.

PCS Interface Programming Guide

For a complete description of the PCS Interface HP-IB commands used in this chapter see chapter 4, "HP-IB Commands".

Conventions Used

Examples given in this chapter will include: the instrument to be programmed, the command string, and the reference page in this manual for the given command string.

For example:

To the PCS Interface> COMP:TEMP:REQ:RES (*page 104*)

or

To the Test Set> RFAN:INP 'Ant'

NOTE:

Reference information (reference page) for the command strings used to program the Test Set are not included in this manual. Refer to your Test Set's programming guide for complete descriptions.

Test Procedure Flow

Figure 24 is an overview of the initialization, set up, and measurement steps required in control software when using a PCS Interface in a test system.

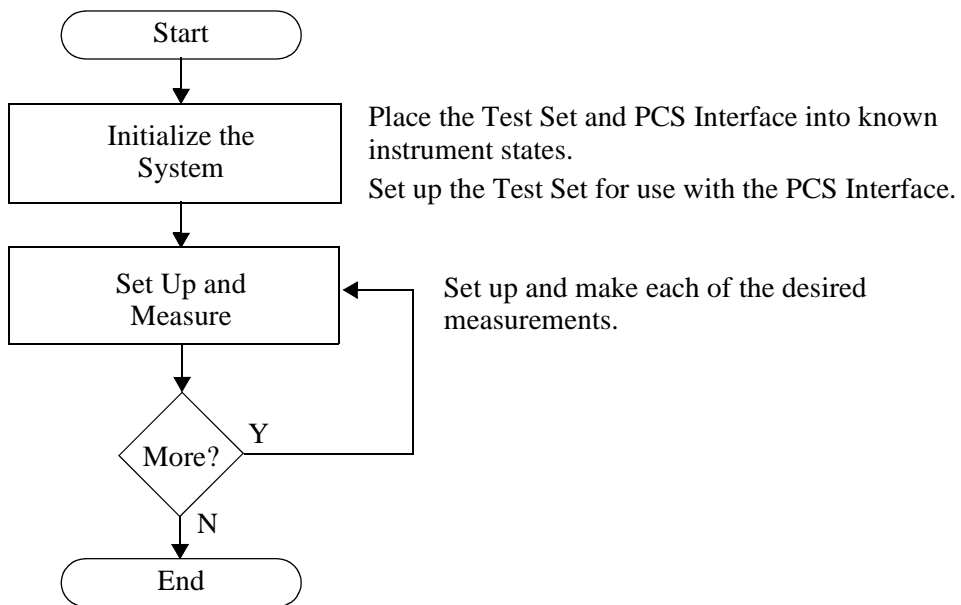

Figure 24

Initialize the System

Figure 25 shows the tasks necessary to initialize the Test System.

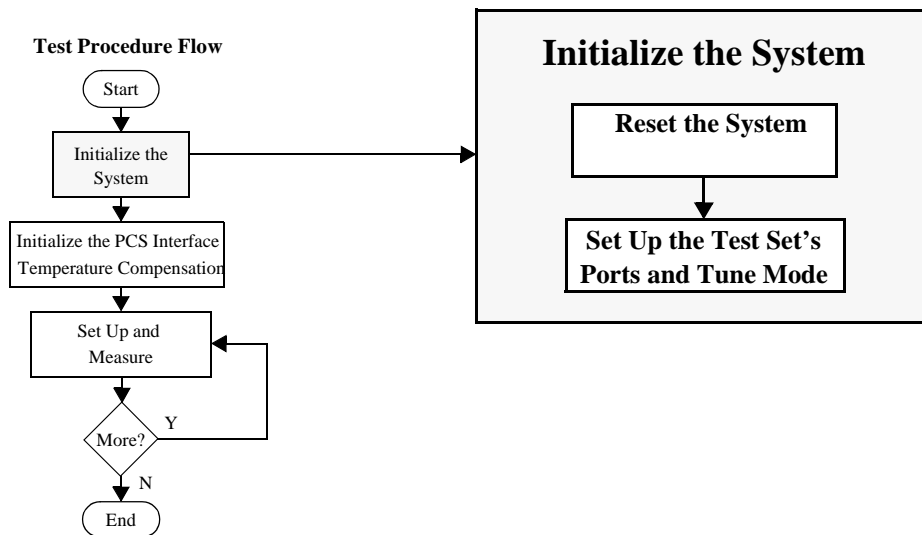

Figure 25

Reset the System

The PCS Interface and the Test Set need to be reset to their default instrument settings.

1. Use the following command string to reset the Test Set and query for completion.
To the Test Set> *RST;*OPC?
2. Use the following command string to reset the PCS Interface and query for completion.
To the PCS Interface> *RST;*OPC? (*page 99*)

Set Up the Test Set's Ports and Tune Mode

When The Test Set was reset in the previous step, its RF IN/OUT port was designated by default. The PCS Interface requires connections to the Test Set's DUPLEX OUT and ANT IN ports.

Placing the Test Set in Manual Tune mode will provide accurate frequency error results when transmitter frequency measurements are made.

1. Use the following command string to set the Test Set's RF analyzer port to ANT IN.

```
To the Test Set>    RFAN:INP 'Ant'
```

2. Use the following command string to set the Test Set's RF generator port to DUPLEX OUT.

```
To the Test Set>    RFG:OUTP 'Dupl'
```

3. Use the following command string to set the Test Set's tune mode to Manual.

```
To the Test Set>    RFAN:TMOD 'Manual'
```

Set Up and Measure

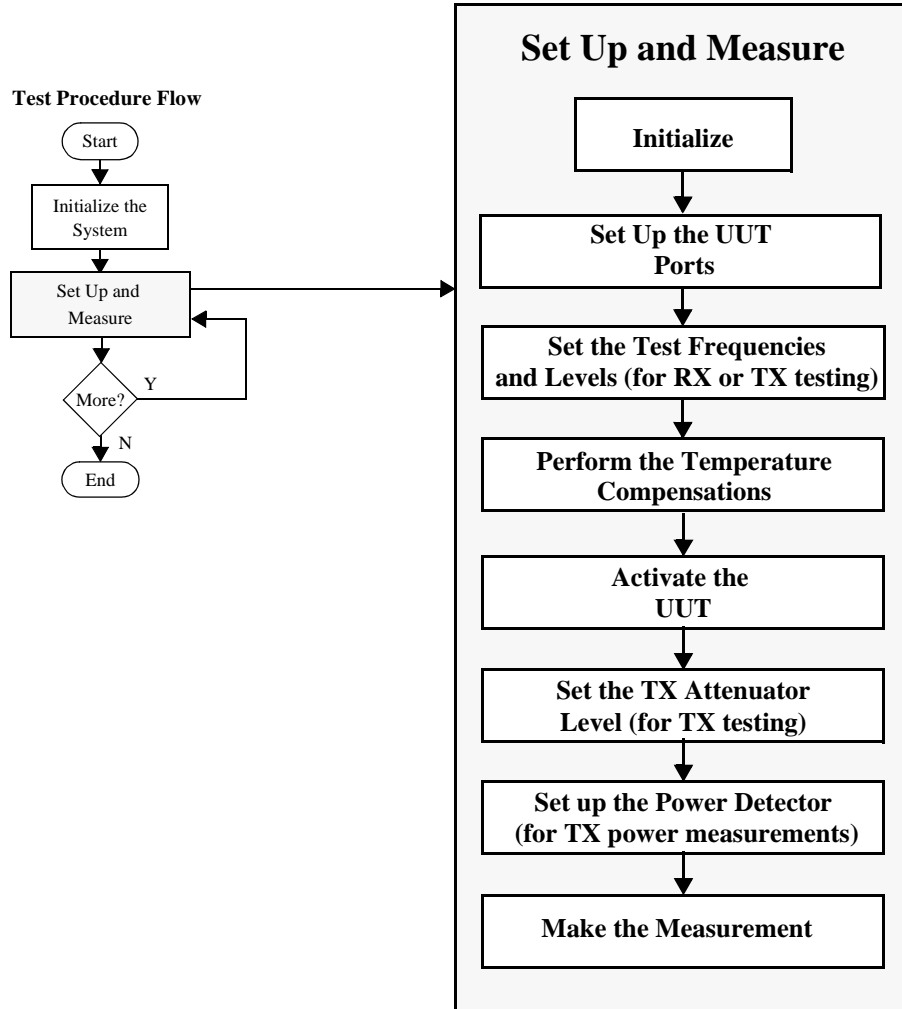

Figure 26

Initialize

1. Use the following command string to initialize the PCS Interface and query for completion.

To PCS Interface> SYST:PRES; *OPC? (page 113)

NOTE:

The SYST:PRES command string will reset the PCS Interface but will maintain the current temperature compensation. Do not use the *RST command during this initialization since it will reset the temperature compensation. Compensations will be done at the first time requested following the *RST command.

Set Up the UUT ports

The internal signal path switches of the PCS Interface can be controlled to route the Test Set's connections to or from the UUT.

1. Use the following command string for RX testing at the PCS Interface's RF OUT only port and for TX testing at the PCS Interface's RF IN/OUT port.

To the PCS Interface> RF:PATH 1 (page 107)

2. Use the following command string for both RX and TX testing at the PCS Interface's RF IN/OUT port.

To the PCS Interface> RF:PATH 2 (page 107)

NOTE:

When the RF:PATH command is executed, the TX and RX attenuators are automatically set to their maximum values of 40 dB and 70 dB, respectively.

Set the Test Frequencies and Levels (for RX or TX testing)

Set the generator frequency for receiver testing

The PCS Interface takes the source signal from the Test Set's DUPLEX OUT port and routes the signal to the UUT port RF OUT only (or RF IN/OUT). Based on the frequency requested at the UUT port, the PCS Interface automatically determines if the upconversion or bypass path is used.

1. Use the following command string to indicate the desired testing frequency at the UUT port and to query the PCS Interface for the corresponding frequency needed at the its FROM DUPLEX OUT port.

```
To the PCS Interface>    RX:TSET:FREQ? <desired frequency>  
(page 111)
```

2. Define a local constant for the frequency obtained in step 1.

```
For example: Duplex_freq
```

3. Use the following command string to set the Test Set's DUPLEX OUT frequency.

```
To the Test Set>    RFG:FREQ <Duplex_freq>
```

NOTE:

Table 14 on page 138 describes the frequency conversions automatically made by the PCS Interface.

Set the generator level for receiver testing

The PCS Interface is designed to optimize the level accuracy of the generator's output. It automatically computes the optimum signal level to set the Test Set's DUPLEX OUT port to in order to obtain the desired signal level at the PCS Interface's UUT port.

NOTE:

Refer to the specifications for the output levels available from both the RF OUT only and RF IN/OUT ports.

1. Use the following command string to indicate the signal level desired at the PCS Interface's UUT port and to query the PCS Interface for the corresponding signal level needed at its FROM DUPLEX OUT port.

```
To the PCS Interface>    RX:TSET:LEV? <desired level>  
(page 112)
```

2. Define a local constant for the signal level obtained in *step 1*.

```
For example: Duplex_lev
```

3. Use the following command string to set the Test Set's DUPLEX OUT level.

```
To the Test Set>    RFG:AMPL <Duplex_lev>
```

NOTE:

Since the level required at the PCS Interface's FROM DUPLEX OUT port is computed as a function of frequency, the generator level should be set *after* the generator frequency is set.

Set the analyzer frequency for transmitter testing

The PCS Interface takes the transmitter output signals from the UUT connected to its RF IN/OUT port and routes the signal to the Test Set's ANT IN port. Based on the frequency requested at the PCS Interface's UUT port, the PCS Interface automatically determines if the downconversion path or bypass path is used.

1. Use the following command string to set the PCS Interface's down-converter for the expected transmitter frequency at the PCS Interface's UUT port and to query the PCS Interface for the corresponding frequency to be expected at the Test Set's ANT IN port.

```
To the PCS Interface> TX:TSET:FREQ? <test frequency>
(page 120)
```

2. Define a local constant for the frequency obtained in *step 1*.

```
For example: Ant_freq
```

3. Use the following command string to tune the Test Set's RF analyzer frequency to the UUT's transmitter frequency.

```
To the Test Set> RFAN:FREQ <Ant_freq>
```

NOTE:

Table 14 on page 138 in the attached appendix describes the conversions for frequency automatically made by the PCS Interface.

Set the analyzer attenuation level if you are establishing an active link between the Test Set and the UUT using over-the-air protocol.

1. If an active link using over-the-air protocol is going to be established between the Test Set and the UUT, the attenuator may need to be set to a minimum value. This will allow the Test Set to receive the UUT's transmitted signal at a high enough level to establish the link.

Use the following command string to set the attenuator of the PCS Interface's analyzer path to 0 dB.

```
To the PCS Interface> TX:OUTP:ATT 0 dB (page 118)
```

Perform the Temperature Compensations

Two temperature compensations are available. The dc offset compensation is required to achieve the most accurate transmitter power measurements. The generator level compensation provides the best generator level accuracy for receiver testing. See "Temperature Compensations" on page 73 for a more detailed description of these two compensations.

Temperature compensation for transmitter testing.

If the power detector in the PCS Interface is to be used for making a transmitter power measurement, both the dc offset temperature compensation and the power detector compensation should be checked and performed if necessary.

1. Use the following command to perform the dc offset temperature compensation.

```
To PCS Interface>      COMP:PDET:DCOF:EXEC      (page 100)
```

Temperature compensation for receiver testing

Since the Test System's source is used for receiver testing, the generator level temperature compensation should be checked and performed, if necessary, prior to making a receiver measurement.

1. Check and see if the generator level temperature compensation is necessary.
 - a. Use the following command to query the PCS Interface for whether generator level compensation is necessary.

```
To PCS Interface>      COMP:TEMP:REQ:STAT?      (page 105)
```

- b. Store the result as a local constant.

```
For example: Status
```

2. If compensation is necessary (for example, Status=1), then set up the Test System for the temperature compensation.
 - a. Use the following command string to indicate the frequency band desired for receiver testing and to query the PCS Interface for the resulting frequency needed at its FROM DUPLEX OUT port.

```
To the PCS Interface>      COMP:TEMP:FREQ? <band or frequency>
(page 102)
```

- b. Define a local constant for the Test Set's DUPLEX OUT frequency obtained in step a.

```
For example: Duplex_freq
```

- c. Use the following command string to set the Test Set's generator frequency.

```
To the Test Set>      RFG:FREQ <Duplex_freq>
```

- d. Use the following command string to query the PCS Interface for the signal level required at its FROM DUPLEX OUT port.

To the PCS Interface> COMP:TEMP:LEV? (*page 103*)

- e. Define a local constant for the level obtained in step d.

For example: Duplex_lev

- f. Use the following command string to set the Test Set's generator level.

To the Test Set> RFG:AMPL <Duplex_lev>

- 3. Use the following command string to perform the generator level temperature compensation.

To the PCS Interface> COMP:TEMP:EXEC? (*page 101*)

Activate the UUT

Activate the RX and/or TX functions of the UUT.

NOTE:

You need to determine the steps required here. You can either control the UUT with the Test Set's call processing capabilities or some other means of direct control.

Set the TX Attenuator Level (for TX testing)

The PCS Interface is designed to optimize the level of the signal passed to the Test Set's RF analyzer. With a single HP-IB command, the PCS Interface will automatically adjust its analyzer path attenuation. This should be performed after the active signal is connected to the RF IN/OUT port.

1. Use the following command string to set the PCS Interface's analyzer path attenuation to obtain the optimum signal level into the Test Set's ANT IN port and to query for completion.

To the PCS Interface> TX:OUTP:LEV:ADJ; *OPC? (page 119)

NOTE:

Do not have a signal generator level greater than -50 dBm at the RF IN/OUT port when adjusting the attenuator level. This may require that you reduce the level of the signal generator.

NOTE:

This is a one time setting and does not place the PCS Interface in an auto-ranging mode. If the TX signal level changes, the attenuation setting command should be sent again.

The optimum level out of the PCS Interface's TO ANT IN port can be modified using the **TX:OUTP:LEV** command, and the **TX:OUTP:RFAN:PATH:IL?** command can return the path loss from the RF IN/OUT port to the TO ANT IN port. These two commands can be used to develop custom attenuator setting procedures in the controlling software which can be used if a known signal level will be connected to the RF IN/OUT port.

Since the attenuator setting is a function of frequency, the analyzer's attenuator should be adjusted after the analyzer's frequency is set.

**Set Up the Power
Detector
(for TX power
measurements)**

Before making a power measurement, the triggering type and data collection conditions must be set and the **TX:INP:FREQ** must be set so the correct compensation factors are applied to the measurement. See table 9 on page 88 for application examples of triggering types and data collection.

1. Select the trigger type
 - **Immediate trigger** - Measurements are started when the instrument is ready after being instructed to make a power measurement. This type should be used for any continuous signal measurement.
 - **Amplitude trigger** - Measurements start when the PCS Interface detects that the positive edge of the pulsed signal crosses the trigger threshold. This trigger mode is useful for signal levels above -5 dBm (.316 mW).
 - **External trigger** - The frame clock output from the TDMA Cellular Adapter provides external trigger control.

NOTE:

The subscriber unit UUT must be in an active link with the Test Set when using the frame clock for external triggering.

Use the following command string to select the trigger type.

To the PCS Interface> TX:INP:POW:TRIG <trigger type>
(page 118)

2. Select the data collection conditions

In addition to the trigger features, a subset of the collected data can be selected for use in power computations using IGNORE, LENGTH, and AVERAGE values.

NOTE: The IGNORE value is valid only for the Internal amplitude trigger or the External trigger.

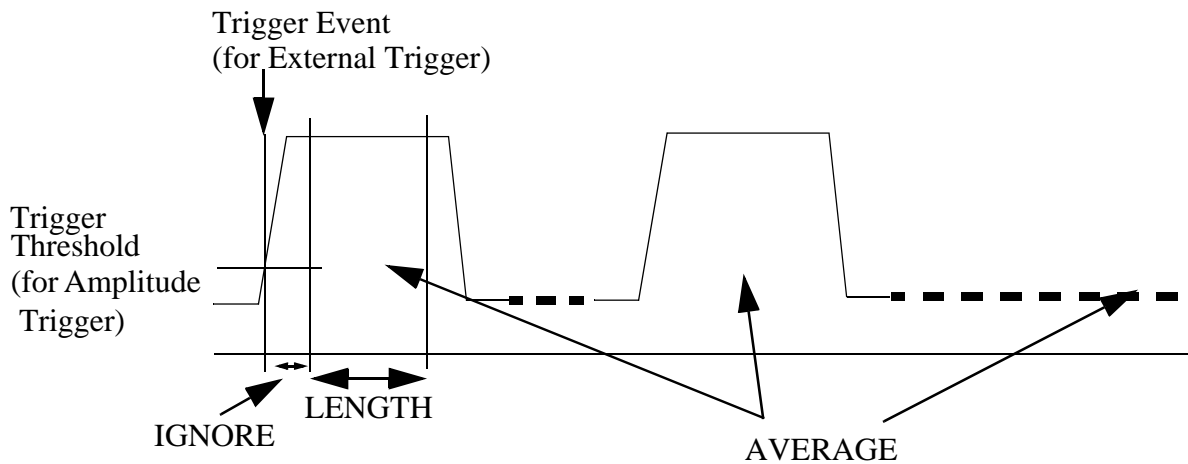

- a. Use the following command string to define the number of measurement samples (ranging from 3 to 3200) (12.5 μ s/sample) to ignore after the trigger conditions have been satisfied.

```
To the PCS Interface> TX:INP:POW:PDET:SAMP:IGN <desired number>
                        (page 117)
```

- b. Use the following command string to define the number of samples to collect (ranging from 1 to 4800) in the measurement after trigger conditions and IGNORE samples have been satisfied.

```
To the PCS Interface> TX:INP:POW:PDET:SAMP:LENG <desired number>
                        (page 117)
```

- c. Use the following command string to define the number of bursts (ranging from 1 to 10) to include in the power measurement. IGNORE and LENGTH conditions will be applied to each burst.

```
To the PCS Interface> TX:INP:POW:PDET:SAMP:AVER <desired number>
                        (page 116)
```

NOTE: If the Immediate trigger is used, up to 48000 samples can be collected by the combination of the LENGTH and AVERAGE values.

Table 9 Example power measurement set ups for typical applications

		TX:INP:POW:PDET:SAMP			TX:INP:POW:TRIG
		:IGN (IGNORE)	:LENG (LENGTH)	:AVER (AVERAGE)	TRIGGERING TYPE
Application	CDMA Base Station	—	4800	4	IMM (Immediate)
	CDMA Subscriber Unit	—	4800	4	IMM (Immediate)
	TDMA Base Station	—	See footnote ¹	1	IMM (Immediate)
	TDMA Subscriber Unit ²	See footnote ³	461	See footnote ¹	EXT (External)
	TDMA Subscriber Unit ² (Signals > -5 dBm)	17	461	See footnote ¹	AMPTD (Amplitude)

1. The total number of points used in the power measurement determines the accuracy achieved. The measurement accuracy is:

$$\pm 5\% \pm \frac{180}{\sqrt{N}} [\mu\text{W}] \text{ This applies @ } 23 \pm 10 \text{ degrees C}$$

$$\pm 10\% \pm \frac{180}{\sqrt{N}} [\mu\text{W}] \text{ This applies @ } 0 \text{ to } 55 \text{ degrees C}$$

Where:

N = total number of points used, or LENGTH*AVERAGE from the table above

2. The PCS Interface's power detector sample rate is 80 kHz. For the US TDMA symbol rate of 24.3 kHz, this implies 3.29 samples/symbol. The values for IGNORE and LENGTH provide power measurements compliant with the IS-137 specification of at least 140 symbols between symbols 6 and 162 in the burst.

3. Since the frame trigger signal from the Cellular Adapter is used for the external trigger, and the subscriber unit is locked to the Test System's frame clock, transmitter power measurements can be made on any of the 6 TDMA slots by adjusting the IGNORE value.

$$\text{IGNORE} = (S * 533) + 2001, \text{ for } S = \text{slot number} = 1, 2$$

$$\text{IGNORE} = (S * 533) - 1197, \text{ for } S = \text{slot number} = 3, 4, 5, 6$$

Make the Measurement

Transmitter power for using the PCS Interface is available in addition to other measurements from the Test Set.

- Transmitter Power measurements

Use the following command string to query the power measurement from the PCS Interface.

To the PCS Interface> TX:INP:POW? (page 115)

NOTE:

The power detector temperature compensation is automatically performed when the TX:INP:POW? command string is used to make a power measurement.

When performing the power measurement, the RF generator level should be set to less than -50 dBm if the RF IN/OUT port is used, or set to less than -30 dBm if the RF OUT only port is used.

- Other Test Set measurements

Refer to the Test Set's programming guide for making other measurements.

NOTE:

Since the Test Set does not automatically correct for the frequency and amplitude changes due to the conversions in the PCS Interface, absolute frequency (using the Auto Tune mode) and absolute amplitude measurements will not be accurate. For example:

Absolute TX frequency = (1050 or 1060 MHz conversion) + Test Set's frequency reading

HP-IB Commands

What's included in this chapter:

- Introduction
- The Syntax of Program Messages
- Reference Information for each HP-IB command
- HP-IB Command Summary

Introduction

The PCS Interface is controlled only by HP-IB commands from the Test Set's internal IBASIC controller or the user-supplied external controller.

The HP-IB commands for the PCS Interface comprise common commands and subsystem commands.

NOTE:

The information in this chapter does *not* apply when an HP 8924C is controlling the PCS Interface over the serial port.

Common Commands

An asterisk (*) is always placed in front of a common command. These common commands conform to IEEE 488.2.

Subsystem Commands

Subsystem commands are hierarchies composed of multiple commands connected by colons. The hierarchies are also called "command trees."

Subsystem Command Trees

The command at the base of a subsystem command tree is called the **root command**, or simply the **root**. (This is similar to the terminology used for the directory path of DOS files.) To indicate the command at the beginning of the tree, the **path** from the root must be specified. Immediately after the power is turned on or a preset is carried out, the root is specified as the current path. The following method can be used to change this path's specification.

Program Message Terminator A program message terminator such as **<new line>** returns the current path to the root.

Colon (:) Inserting a colon between two commands causes the current path to branch one level down. If a colon is placed in front of a command it indicates that the command is the root command.

Semicolon (;) A semicolon indicates the separation of two groups of commands. A semicolon does not change the specification of the current path.

An example of how colons and semicolons are used within a command tree is shown in figure 27 on page 93.

Common commands such as *RST may not be used in a subsystem. Common commands function regardless of the current specified path.

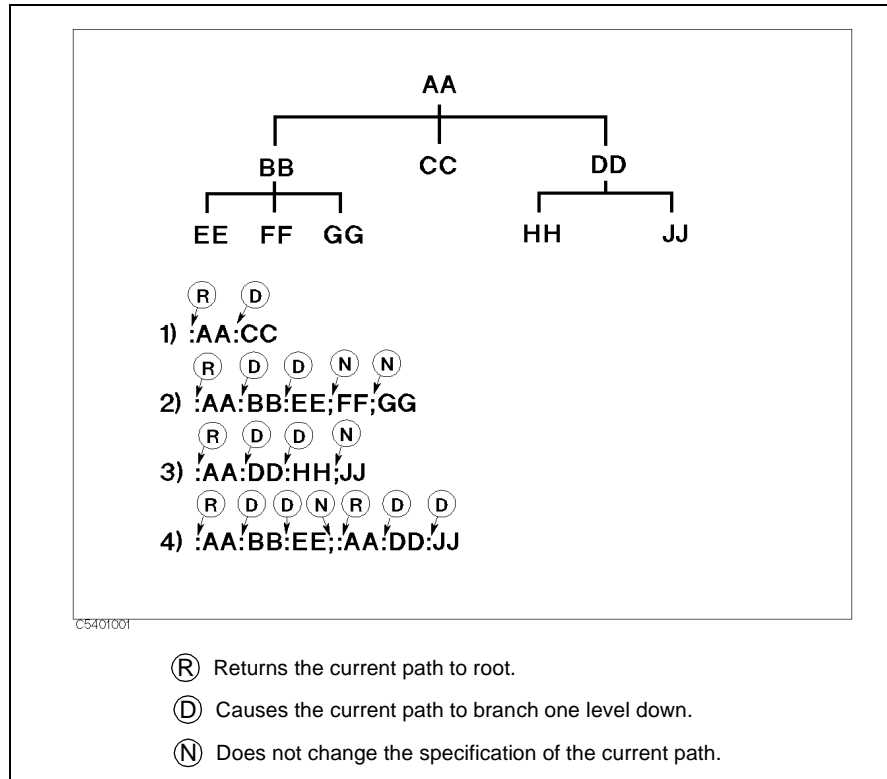

Figure 27

The Correct Use of Colons and Semicolons

Command Abbreviations

Abbreviations can be used for some commands. This manual does not use abbreviations for commands when describing them. However, the letters that are used in the abbreviation of the command appear in uppercase, and the letters that must be omitted to form the abbreviation appear in lowercase.

For example, this manual indicates that the abbreviation of the command **:SYSTEM** is **:SYST** by showing it as **:SYSTEM**. (Abbreviations such as **:SYSTE** are not valid.)

The Syntax of Program Messages

This section details the format and parameters of program messages.

Program messages are sent by the computer to the measuring device. They are comprised of one or more commands, the symbols that separate each command, and a message termination symbol (terminator).

Uppercase and Lowercase Letters

No distinction is made between uppercase and lowercase letters in program messages.

Program Message Terminator

The **program message terminators** are <newline>, <^END>, and <newline><^END>. <^END> is used to indicate the end of a program message. <^END> means that an EOI (End Of Identify) was transmitted, signaling that data transmission through an HP-IB interface has been completed.

For example, the **HP BASIC OUTPUT** statement automatically adds an <^END> to the end of data transmissions. For IBM PC computers, the specification for the terminator that is transmitted can be changed by changing the environment settings of the system.

Multi-messages

More than one command can be included in a message. When this is done a semicolon is used to separate the commands.

*RST;*IDN?

The Syntax of Query Messages and Response Messages

Commands other than those described in the command reference as “No Query” can be used as Query commands. To send a Query command as a message, add a ? to the end of the character string as shown in the example below.

*IDN?

Commas and semicolons are used to separate data in response messages. Commas are used to separate multiple return values in response to a Query command. Semicolons are used to separate the responses to multiple Query commands transmitted as one message. As an example, the response to the message **:QUERY1?;QUERY2?** is shown below.

<data1>,<data1>;<data2>,<data2>

<newline><^END> is transmitted at the end of the message to indicate the end of the message.

Parameters

One *<space>* has to be inserted between the command character string of the subsystem and the first parameter.

When more than one parameter has to be added to a command, commas are used to separate the parameters.

Types of Parameters

Command parameters have many formats. Previously defined fixed formats that correspond to each command are used in the replies. The formats that may be used for each command are noted in the command reference.

- The use of one of the following numeric formats is indicated by *<numeric>*.

100	no decimal point
100.	with decimal point
-1.23, +235	with a minus or plus sign
4.56e 3	exponential expression with a space after the e
-7.89E-01	exponential expression with an E or an e
.5	only to the right of the decimal point

There is a limit to the numeric formats that can be used when using a program to specify the settings of the PCS Interface. A “rounding-off” operation is automatically carried out if a specified parameter exceeds this limit. *<numeric>* data that is in response to a Query command is always in an *<NR1>* (integer) or an *<NR3>* (decimal point) format.

- Suffixes

When a suffix has to be used with a command, multiplier suffixes (such as **K** for kilo) and unit suffixes can be used. (If a multiplier suffix is used, it must be accompanied by a unit suffix, such as HZ.)

Frequency: **HZ** (Hz; default setting), **KHZ** (kHz), **MAHZ** or **MHZ** (MHz), **GHZ** (GHz)

Power: **DBM** (dBm; default setting), **W** (W)

Temperature: **DEG** (°C; default setting)

Suffixes may be omitted. If they are, the default suffixes will be used.

Common Commands

*IDN?

Returns the ID of the PCS Interface. (Query only)

- Response to the Query

HEWLETT-PACKARD,HP83236B,xxxxxxxx,REV,yy.yy <newline><^END>

where, *xxxxxxxx* is a serial number and *yy.yy* is a firmware version.

*OPT?

Returns the options that are installed. (Query only)

NO OPTION: The frequency range is limited. See "Change 1" on page 145 for details.

WIDE BAND: All of the frequency range documented in this manual can be used.

- Response to the Query

{NO OPTION|WIDE BAND} <newline><^END>

***RST**

Returns all of the settings of the PCS Interface to their default settings. (No Query)

Table 10

SYST:PRES Command Settings

Command	Setting
COMP:PDET:DCOF:REQ:RES	1
COMP:PDET:TEMP:REQ:RES	1
COMP:TEMP:REQ:RES	1
RF:PATH	0
RX:OUTP:ATT	70 dB
RX:OUTP:FREQ	1930 MHz
RX:OUTP:LEV	-130 dBm
TX:INP:FREQ	1850 MHz
TX:INP:POW:PDET:SAMP:AVER	1 (for the Immediate Trigger) 5 (for the Amplitude or External Trigger)
TX:INP:POW:PDET:SAMP:IGN	17
TX:INP:POW:PDET:SAMP:LENG	4800 (for the Immediate Trigger) 461 (for the Amplitude or External Trigger)
TX:INP:POW:TRIG	IMM
TX:INP:POW:UNIT	dBm
TX:OUTP:ATT	40 dB
TX:OUTP:LEV	-9 dBm

COMPensation Subsystem

COMPensation:PDET:DCOOffset:EXECute

This command measures the dc offset values of the power detector. The dc offset value is used to calculate the measurement value from the actual output value of the power detector. This is the equivalent of zeroing the power meter.

NOTE:

The dc offset values are also updated at power-up of the PCS Interface or after executing the *RST command or the **COMP:TEMP:EXEC?** command.

The query form of this command is used to measure the current temperature value and compare it to the value stored the last time dc offset values were measured. When the difference is greater than or equal to the value set by the **COMP:PDET:DCOF:REQ:RES** command, the PCS Interface stores the current value, and returns 1 (TRUE). If the difference is less than the value set by the **COMP:PDET:DCOF:REQ:RES** command, the PCS Interface does nothing and only returns 0 (FALSE).

- Response to the Query

{0|1} <new line><^END>

- 0:** The PCS Interface did nothing, because the temperature change is less than the value defined by the **COMP:PDET:DCOF:REQ:RES** command.
- 1:** The PCS Interface measures the dc offset of the power detector and stores the measured values into the non-volatile memory, because the temperature change is larger than the value defined by the **COMP:PDET:DCOF:REQ:RES** command.

COMPensation:PDET:DCOffset:REQuest:RESolution [] <numeric>[DEG]

This command specifies the threshold value of the temperature change used to judge whether the update of the dc offset values of the power detector is required.

<numeric>: Greater than or equal to 0 in 0.1°C steps.

If 0 is set, the temperature compensation is always required.

- Response to the Query
{numeric} <new line><^END>

COMPensation:PDET:TEMPerature:REQuest:RESolution [] <numeric>[DEG]

This command specifies the threshold value of the temperature change used to judge whether the update of the voltage-power characteristics of the power detector is required.

<numeric>: Greater than or equal to 0 in 0.1°C steps.

If 0 is set, the temperature compensation is always required.

- Response to the Query
{numeric} <new line><^END>

COMPensation[:RFG1]:TEMPerature:EXECute?

This command performs the generator level temperature compensation, and it returns the signal path to the previous setting. (Query only)

NOTE:

Before executing this command, execute the **COMP:TEMP:FREQ?** [] {0|1|2|3|4|5} and the **COMP:TEMP:LEV?** command and input the specified frequency and signal level to the FROM DUPLEX OUT port.

- Response to the Query
{0|1} <new line><^END>
0: Executed the temperature compensation but did not re-write the data, because the measurement data values exceeds the internal limits. The possible reason is that the cable connections are not correct or that the level of the input signal to the FROM DUPLEX OUT port is not correct.
1: Executed the temperature compensation and re-wrote the data.

COMPensation[:RFG1]:TEMPerature:FREQuency? []
[{0|1|2|3|4|5}<numeric>[HZ|KHZ|MAHZ|MHZ|GHZ]]

This command returns the frequency required at the FROM DUPLEX OUT port for the temperature compensation for the RF signal generator to provide the optimum output level accuracy. If the frequency band or value is not specified, the frequency value specified by the **RX:OUTP:FREQ** is used. (Query only)

0:	800 to 859 MHz band (Compensation frequency: 840 MHz)
1:	859 to 960 MHz band (Compensation frequency: 880 MHz)
2:	1710 to 1785 MHz band (Compensation frequency: 1750 MHz)
3:	1805 to <1850 MHz band (Compensation frequency: 1830 MHz)
4:	1850 to 1910 MHz band (Compensation frequency: 1880 MHz)
5:	1930 to 1990 MHz band (Compensation frequency: 1960 MHz)
<numeric>:	800 to 859 MHz, 859 to 960 MHz, 1710 to 1785 MHz, 1805 to 1850 MHz, 1850 to 1910 MHz, 1930 to 1990 MHz (Compensation frequency is rounded off to 840 MHz, 880 MHz, 1750 MHz, 1830 MHz, 1880 MHz, or 1960 MHz.) If the entered value is out of range, the value is rounded off to the appropriate limit value. (The default unit is “Hz”).

Supply the signal whose frequency and level are returned by this command and the **COMP:TEMP:LEV?** command to the FROM DUPLEX OUT port. Then execute the **COMP:TEMP:EXEC?** command to execute the RF generator temperature compensation.

- Response to the Query
{numeric (Hz)} <new line><^END>

COMPensation[:RFG1]:TEMPerature:LEVel?

This command sets the signal path for the temperature compensation, and returns the level required at the FROM DUPLEX OUT port for the temperature compensation for the RF signal generator to provide optimum output level accuracy. The band must be specified by executing the **COMP:TEMP:FREQ?** [] {0|1|2|3|4|5|<numeric>} to specify the frequency before executing this command. (Query only)

Supply the signal whose frequency and level are returned by this command and the **COMP:TEMP:FREQ?** [] {0|1|2|3|4|5|<numeric>} command to the FROM DUPLEX OUT port. Then execute the **COMP:TEMP:EXEC?** command to execute the RF generator temperature compensation.

- Response to the Query
{numeric (dBm)} <new line><^END>

COMPensation[:RFG1]:TEMPerature:PDETector:SAMPLE:AVERage[:FACTor] [] <numeric>

Specifies the number of bursts to be measured to calculate the average value of the dc offset measurement.

<numeric>: 1 to 10

If the entered value is out of range, the value is rounded off to the appropriate limit value.

- Response to the Query
{numeric} <new line><^END>

COMPensation[:RFG1]:TEMPerature:PDETector:SAMPLE:LENGth [] <numeric>

Specifies the number of A/D conversion samples to be used to calculate the measurement value of the dc offset measurement. (The sampling time is 12.5 μ s.)

<numeric>: 1 to 4800

If the entered value is out of range, the value is rounded off to the appropriate limit value.

- Response to the Query
{numeric} <new line><^END>

COMPensation[:RFG1]:TEMPerature:REQuest:RESolution [] <numeric>[DEG]

This command specifies the threshold value of the temperature change to judge whether an update of the RF generator compensation factors are required. (This value is used by the COMP:TEMP:REQ:STAT? command.)

<numeric>: Greater than or equal to 0 in 0.1 °C steps.

If 0 is set, the temperature compensation is always required.

- Response to the Query
{numeric} <new line><^END>

COMPensation[:RFG1]:TEMPerature:REQuest:STATe?
[[0|1|2|3|4|5]<numeric>[HZ|KHZ|MAHZ|MHZ|GHZ]]

Used to check if the RF generator compensations at the specified frequency band or value are required based on the temperature change since the last compensation. If the frequency band or value is not specified, the frequency value specified by the **RX:OUTP:FREQ** is used. This command measures the current temperature and compares it to the previously stored value. (Query only)

- 0:** 800 to 859 MHz band (Compensation frequency: 840 MHz)
- 1:** 859 to 960 MHz band (Compensation frequency: 880 MHz)
- 2:** 1710 to 1785 MHz band (Compensation frequency: 1750 MHz)
- 3:** 1805 to <1850 MHz band (Compensation frequency: 1830 MHz)
- 4:** 1850 to 1910 MHz band (Compensation frequency: 1880 MHz)
- 5:** 1930 to 1990 MHz band (Compensation frequency: 1960 MHz)
- <numeric>:** 800 to 859 MHz, 859 to 960 MHz, 1710 to 1785 MHz, 1805 to 1850 MHz, 1850 to 1910 MHz, 1930 to 1990 MHz (Compensation frequency is rounded off to 840 MHz, 880 MHz, 1750 MHz, 1830 MHz, 1880 MHz, or 1960 MHz.) If the entered value is out of range, the value is rounded off to the appropriate limit value. (The default unit is “Hz”.)

- Response to the Query

{0|1} <new line><^END>

- 0:** The temperature change is less than the value defined by the **COMP:TEMP:REQ:RES** command. The temperature compensation is *not* required.
- 1:** The temperature change is greater than the value defined by the **COMP:TEMP:REQ:RES** command. The temperature compensation is required.

RF Subsystem

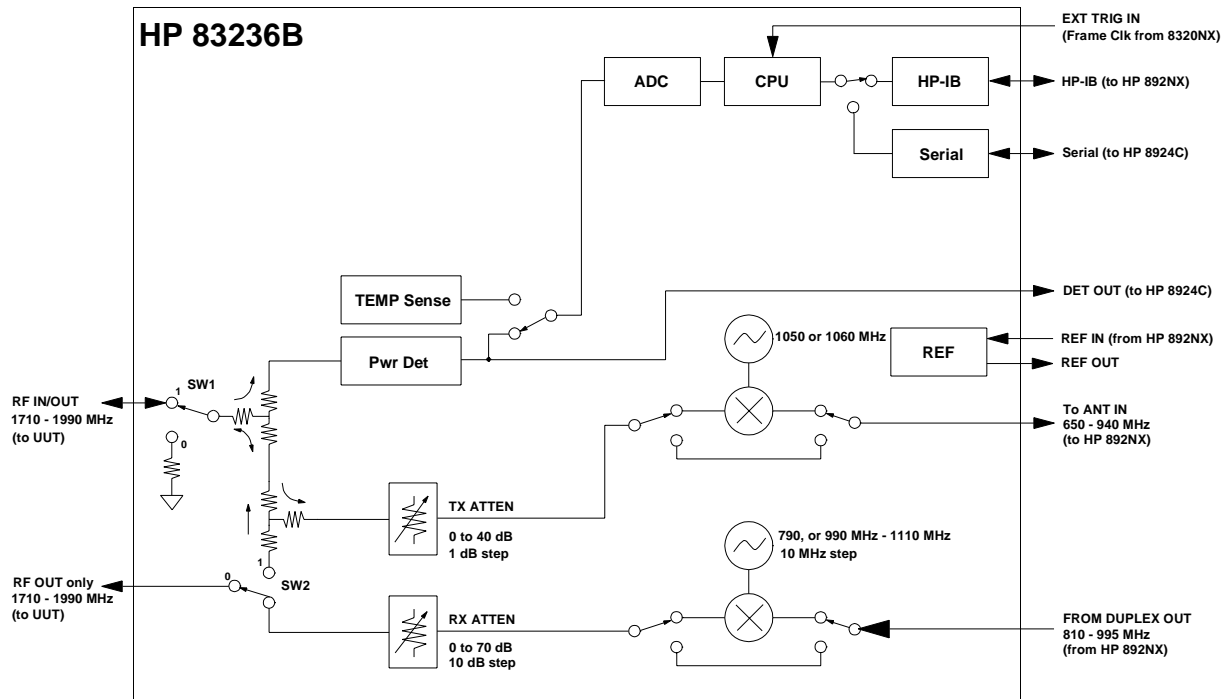

RF:PATH [] {0|1|2}

Selects the signal path.

NOTE:

When this command is executed, the value of the TX attenuator is set to 40 (dB) and the RX attenuator is set to 70 (dB).

Table 11 RF Path Setting

Parameter	SW1	SW2	RF IN/OUT ⇒ TO ANT IN & Power detector	FROM DUPLEX OUT ⇒ RF OUT Only	FROM DUPLEX OUT ⇒ RF IN/OUT	FROM DUPLEX OUT ⇒ Power detector
0	0	1				√
1	1	0	√	√		
2	1	1	√		√	√

- Response to the Query
 {-1|0|1|2} <newline><^END>
 -1 indicates that it is an undefined signal path.

RX Subsystem

The RX Subsystem carries out the settings for controlling the PCS Interface's generator path used for the receiver testing.

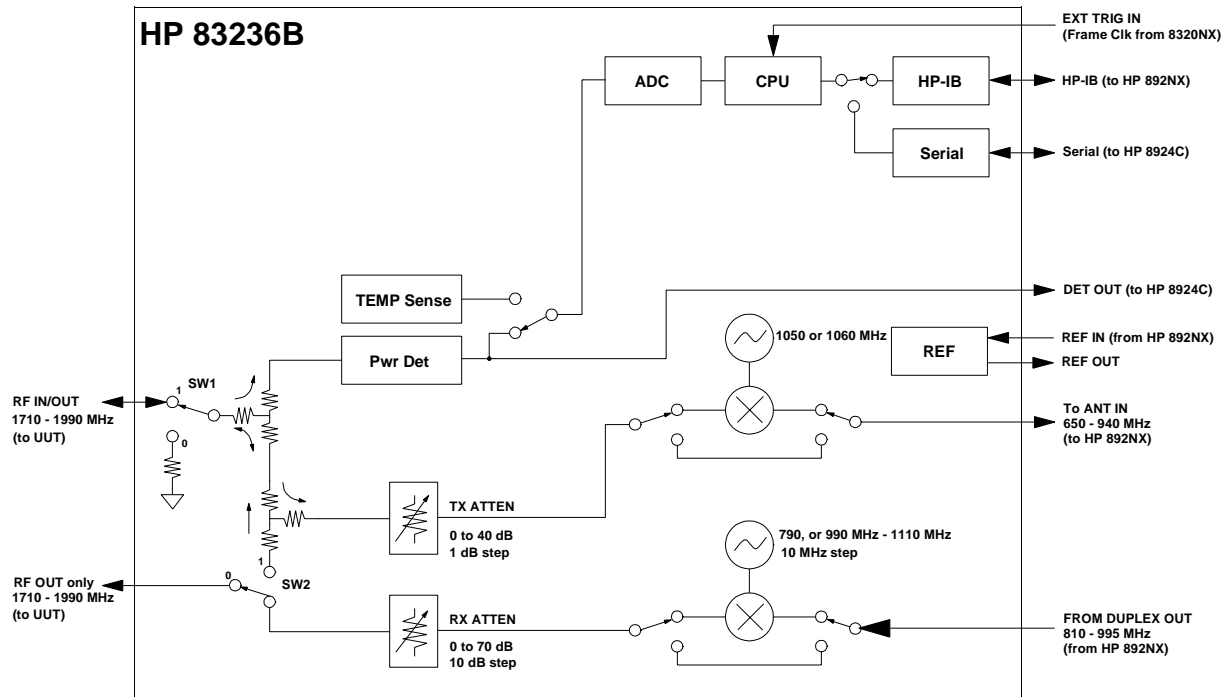

RX[:RFG1]:INPut:FREQuency?

Returns the frequency required at the FROM DUPLEX OUT port. (Query only)

Before executing this command, specify the frequency of the signal which you want to output at the RF IN/OUT or RF OUT only port using the **RX:OUTP:FREQ** command.

- Response to the Query
{numeric (Hz)} <new line><^END>

NOTE:

Use the **RX:TSET:FREQ?** command which has the functions of both the **RX[:RFG1]:OUTP:FREQ** and **RX[:RFG1]:INP:FREQ?** commands.

RX[:RFG1]:INPut:LEVel?

Returns the level required at the FROM DUPLEX OUT port. (Query only)

Before executing this command, specify the level of the signal which you want to output at the RF IN/OUT or RF OUT only port using the **RX:OUTP:LEV** command.

- Response to the Query
{numeric (dBm)} <new line><^END>

NOTE:

Use the **RX:TSET:LEV?** command which has the functions of both the **RX[:RFG1]:OUTP:LEV** and **RX[:RFG1]:INP:LEV?** command.

RX[:RFG1]:OUTPut:ATTenuator [] {0|10|20|30|40|50|60|70}[DB]

Specifies the value of the RX attenuator.

NOTE:

This command is not generally needed because the attenuator level is automatically set when using the **RX:TSET:LEV?** or **RX:OUTP:LEV** command.

- Response to the Query
{numeric (dB)} <new line><^END>

RX[:RFG1]:OUTPut:ATTenuator:MODE {**AUTO**|**HOLD**}

Specifies the selection mode of the RX attenuator.

AUTO: Auto mode. (Default setting.)

HOLD: Hold mode. The attenuator value can be set by the **RX:OUTP:ATT** command.

NOTE:

This command is not generally needed because the attenuator level is automatically set when using the **RX:TSET:LEV?** or **RX:OUTP:LEV** command.

- Response to the Query
{**AUTO**|**HOLD**} <new line><^END>

RX[:RFG1]:OUTPut:FREQuency <numeric> [**HZ**|**KHZ**|**MAHZ**|**MHZ**|**GHZ**]

Specifies the frequency of the signal which you want to output from the RF IN/OUT or RF OUT only port.

<numeric>: 800 to 960 MHz, 1710 to 1785 MHz, 1805 to 1910 MHz, or 1930 to 1990 MHz. If the entered value is out of range, the value is rounded off to the appropriate limit value. (The default unit is “Hz”.)

- Response to the Query
{numeric (Hz)} <new line><^END>

NOTE:

Use the **RX:TSET:FREQ?** command which has the functions of both the **RX:OUTP:FREQ** and **RX:INP:FREQ?** commands.

RX[:RFG1]:OUTPut:LEVel [] <numeric>[DBM]

Specifies the level of the signal which you want to output from the RF IN/OUT or RF OUT only port.

<numeric> -130 to -10 dBm for RF:PATH 1
-130 to -20 dBm for RF:PATH 0 and 2

If the entered value is out of range, the value is rounded off to the appropriate limit value.

- Response to the Query

{numeric (dBm)} <new line><^END>

NOTE:

Use the **RX:TSET:LEV?** command which has the functions of both the **RX:OUTP:LEV** and **RX:INP:LEV?** command.

RX[:RFG1]:TSET:FREQuency? [] <numeric>[HZ|KHZ|MAHZ|MHZ|GHZ]

Specifies the frequency of the signal which you want to output from the RF IN/OUT or RF OUT only port, and returns the frequency required at the FROM DUPLEX OUT port, when the frequency of the wanted signal at the RF IN/OUT or RF OUT only is specified in **<numeric>**. (Query only)

<numeric>: 800 to 960 MHz, 1710 to 1785 MHz, 1810 to 1910 MHz, or 1930 to 1990 MHz (The default unit is “Hz”.)

If the entered value is out of range, the value is rounded off to the appropriate limit value.

- Response to the Query

{numeric (Hz)} <new line><^END>

RX Subsystem

RX[:RFG1]:TSET:LEVel? [*numeric*][DBM]

Specifies the level of the signal which you want to output from the RF IN/OUT or RF OUT only port, and returns the level required at the FROM DUPLEX OUT port, when the level of the wanted signal at the RF IN/OUT or RF OUT only is specified in *numeric*. (Query only)

<numeric>: -130 to -10 dBm for RF:PATH 1

-130 to -20 dBm for RF:PATH 2

If the entered value is out of range, the value is rounded off to the effective limit value.

- Response to the Query
{ numeric (dBm)} <new line><^END>

SYSTem Subsystem

SYSTem:ERRor?

Outputs error messages. (Query only)

- Response to the Query
 {numeric (error code)} {character string (error message)} <new line><^END>
 Refer to "Error Messages" on page 153 for a description of the each error message.

SYSTem:PRESet

Presets the PCS Interface. (No Query)

Table 12 SYST:PRES Command Settings

Command	Setting
COMP:PDET:DCOF:REQ:RES	Current Setting
COMP:PDET:TEMP:REQ:RES	Current Setting
COMP:TEMP:REQ:RES	Current Setting
RF:PATH	0
RX:OUTP:ATT	70 dB
RX:OUTP:FREQ	1930 MHz
RX:OUTP:LEV	-130 dBm
TX:INP:FREQ	1850 MHz
TX:INP:POW:PDET:SAMP:AVER	1 (for the Immediate Trigger) 5 (for the Amplitude or External Trigger)
TX:INP:POW:PDET:SAMP:IGN	17
TX:INP:POW:PDET:SAMP:LENG	4800 (for the Immediate Trigger) 461 (for the Amplitude or External Trigger)
TX:INP:POW:TRIG	IMM
TX:INP:POW:UNIT	dBm
TX:OUTP:ATT	40 dB
TX:OUTP:LEV	-9 dBm

TX Subsystem

The TX Subsystem sets the PCS Interface's analyzer path for the transmitter measurements.

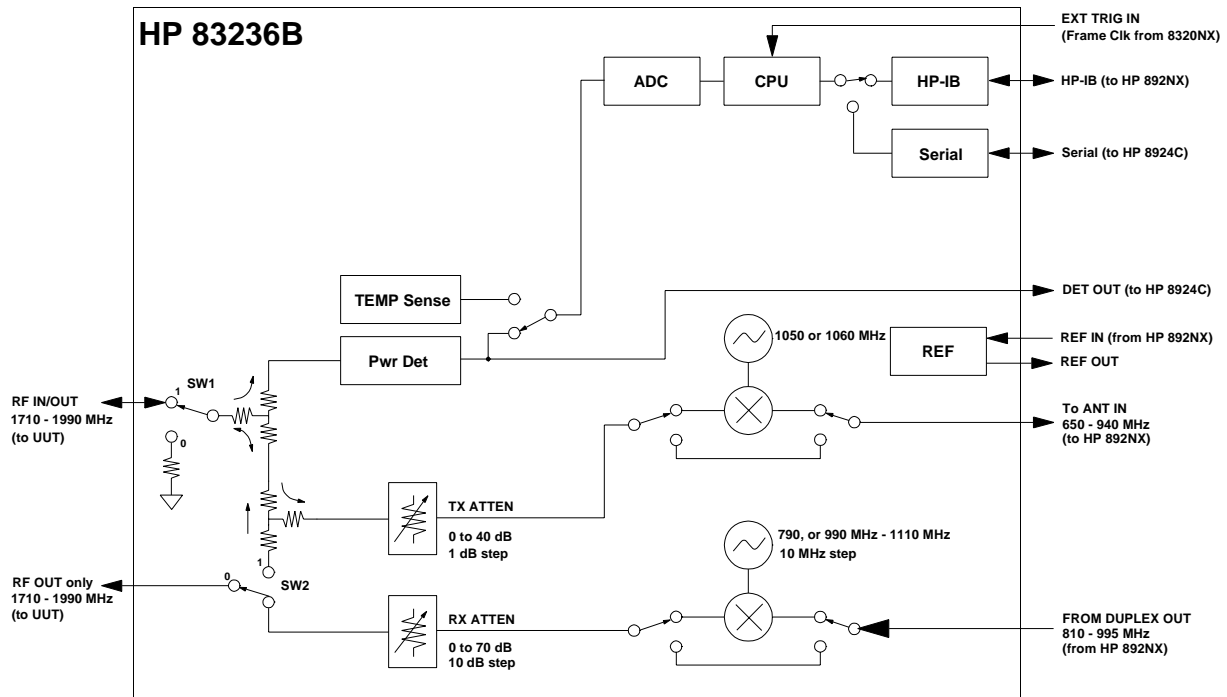

TX:INPut:FREQuency [] <numeric> [HZ|KHZ|MAHZ|MHZ|GHZ]

Specifies the frequency of the signal input to the RF IN/OUT port.

<numeric>: 800 to 960 MHz, 1710 to 1785 MHz, 1805 to 1910 MHz, or 1930 to 1990 MHz (The default unit is “Hz”.)

If the entered value is out of range, the value is rounded off to the appropriate limit value.

- Response to the Query
{numeric (Hz)} <new line><^END>

NOTE:

Use the **TX:TSET:FREQ?** command which has the functions of both the **TX:INP:FREQ** and **TX:OUTP:FREQ?** command.

TX:INPut:POWer?

Performs the temperature compensation for the power detector, measures the average power of the burst of the signal input to the RF IN/OUT port, and returns the value to the controller. The trigger source which decides the timing of the actual power measurement is set by the **TX:INP:POW:TRIG** command. (Query only)

This command is valid only when the **RF:PATH** setting is 1 or 2.

- Response to the Query
{numeric (dBm or W)} <new line><^END>

The unit suffix (dBm or W) is specified by the **TX:INP:POW:UNIT** command. (The default is dBm.)

If the measured data is invalid, -130 (dBm) or 0 (W) is returned. If no trigger is received for the amplitude trigger or the external trigger, -201 is returned.

NOTE:

This command is equivalent to performing both **TX:INP:POW:EXEC** and **TX:INP:POW:EXEC?**.

TX:INPut:POWer:EXEC

Performs the temperature compensation for the power detector, measures the average power of the burst of the signal input to the RF IN/OUT port, and stores the value into the internal buffer memory. The trigger source which decides the timing of the actual power measurement is set by the **TX:INP:POW:TRIG** command.

This command is valid only when the **RF:PATH** setting is 1 or 2.

TX:INPut:POWer:EXEC?

Returns the average power value measured by the **TX:INP:POW:EXEC** command and stored into the internal buffer memory. (Query only)

- Response to the Query

{numeric (dBm or W)} <new line><^END>

The unit suffix (dBm or W) is specified by the **TX:INP:POW:UNIT** command. (The default is dBm.)

If the measured data is invalid, -130 (dBm) or 0 (W) is returned.

TX:INPut:POWer:PDEtector:SAMPle:AVERage[:FACTor] [] <numeric>

Specifies the number of bursts to be measured to calculate the average value of the power measurement.

<numeric>: 1 to 10

If the entered value is out of range, the value is rounded off to the appropriate limit value.

- Response to the Query

{numeric} <new line><^END>

NOTE:

The number of samples to be collected is calculated by the following equation. The **LENGTH** value is set by the **TX:INP:POW:PDET:SAMP:LENG** command and the **IGNORE** value set by the **TX:INP:POW:PDET:SAMP:IGN** command.

$$\text{Number of samples} = \text{LENGTH value} * \text{AVERAGE value}$$

TX:INPut:POWer:PDETEctor:SAMPlE:IGNore \square *<numeric>*

Specifies the number of the A/D conversion samples to ignore after the positive edge trigger. (The sampling time is 12.5 μ s.)

This command is valid only when the **TX:INP:POW:TRIG** command is set to **AMPTD** or **EXT**.

<numeric>: 3 to 3200.

If the entered value is out of range, the value is rounded off to the appropriate limit value.

- Response to the Query
{numeric} <new line><^END>

NOTE:

The following equation shows the relationship between the IGNORE value set by the **TX:INP:POW:PDET:SAMP:IGN** command and the LENGTH value set by the **TX:INP:POW:PDET:SAMP:LENG** command.

$$\text{IGNORE value} + \text{LENGTH value} \leq 4800$$

TX:INPut:POWer:PDETEctor:SAMPlE:LENGth \square *<numeric>*

Specifies the number of A/D conversion samples to be used to calculate the measurement value of the power measurement. (The sampling time is 12.5 μ s.)

<numeric>: 1 to 4800

If the entered value is out of range, the value is rounded off to the appropriate limit value.

- Response to the Query
{numeric} <new line><^END>

TX Subsystem

TX:INPut:POWer:TRIGger[:SOURce] [] {AMPTD|EXT|IMM}

Selects the trigger source to initiate the power measurement after the **TX:INP:POW?** command is sent.

AMPTD: Executes the power measurement when a signal greater than -5 dBm is input to the RF IN/OUT port (amplitude trigger).

EXT: Executes the power measurement when a TTL level signal is input to the EXT TRIG IN port (external trigger).

IMM: Executes the power measurement immediately (immediate trigger).

- Response to the Query

{AMPTD | EXT | IMM} <new line><^END>

TX:INPut:POWer:UNIT [] {DBM|W}

Specifies the measurement units for the input signal's power result returned by the **TX:INP:POW?** command.

DBM: dBm

W: W (Watt)

- Response to the Query

{DBM | W} <new line><^END>

TX:OUTPut[:RFANalyzer]:ATTenuator [] <numeric>[DB]

Specifies the TX path attenuator value.

<numeric>: 0 to 40 dB in 1 dB steps.

If the entered value is out of range, the value is rounded off to the appropriate limit value.

NOTE:

This command is not generally needed to set the level because the attenuator is automatically set when using the **TX:OUTP:LEV:ADJ** command.

- Response to the Query

{numeric (dB)} <new line><^END>

TX:OUTPut[:RFANalyzer]:FREQuency?

Returns the frequency of the output signal at the TO ANT IN port. (Query only)

Before executing this command, specify the frequency to be input to the RF IN/OUT port using the **TX:INP:FREQ** command.

- Response to the Query
{numeric (Hz)} <new line><^END>

NOTE:

Use the **TX:TSET:FREQ?** command which has the functions of both the **TX:INP:FREQ** and **TX:OUTP:FREQ?** command.

TX:OUTPut[:RFANalyzer]:LEVel [] <numeric>[DBM]

Specifies the peak level which you want to output to the TO ANT IN port. Use the **TX:OUTP:LEV:ADJ** command to automatically adjust the TX attenuator to output this signal level from the TO ANT IN port.

<numeric>: -10 dBm to 0 dBm

If the entered value is out of range, the value is rounded off to the appropriate limit value.

- Response to the Query
{numeric (dBm)} <new line><^END>

TX:OUTPut[:RFANalyzer]:LEVel:ADJust

Sets the TX attenuator value so that the signal level output to the TO ANT IN port becomes the level specified by the **TX:OUTP:LEV** command ± 1 dB. (No Query)

This command is valid only when the setting of **RF:PATH** is 1 or 2.

TX Subsystem

TX:OUTPut[:RFANalyzer]:PATH:ILoss? [] <numeric> [HZ|KHZ|MAHZ|MHZ|GHZ]

Returns the value of the insertion loss of the signal path for the RF signal analyzer, when the frequency of the input signal to the RF IN/OUT port is specified by <numeric>. This command is used to calculate the RF power using the Test Set. (Query only)

This command is valid only when the setting of **RF:PATH** is 1 or 2.

<numeric>: 800 to 960 MHz or 1710 to 1990 MHz (The default unit is “Hz”.)

- Response to the Query
{numeric (dB)} <new line><^END>

TX:TSET:FREQuency? [] <numeric> [HZ|KHZ|MAHZ|MHZ|GHZ]

Performs the temperature compensation for the power detector, and returns the frequency which will be output to the TO ANT IN port, when the frequency of the input signal to the RF IN/OUT is specified in <numeric>. (Query only)

<numeric>: 800 to 960 MHz or 1710 to 1990 MHz (The default unit is “Hz”.)

- Response to the Query
{numeric (Hz)} <new line><^END>

Chapter 4, HP-IB Commands
HP-IB Command Summary

Command	Parameter	Note
RX [:RFG1] (continued) :TSET :FREQUENCY? :LEVEL?	 <numeric> <numeric>	 Query only Query only
SYSTEM :ERROR? :PRESET		Query only No Query
TX :INPUT :FREQUENCY :POWER? :POWER :EXECUTE :EXECUTE? :PDETECTOR :SAMPLE :AVERAGE[:FACTOR] :IGNORE :LENGTH :TRIGGER[:SOURCE] :UNIT :OUTPUT [:RFANALYZER] :ATTENUATOR :FREQUENCY? :LEVEL :ADJUST :PATH :ILOSS? :TSET :FREQUENCY?	 <numeric> <numeric> <numeric> <numeric> { AMPTD EXT IMM } { DBM W } <numeric> <numeric> <numeric> <numeric>	 Query only No Query Query only Query only No Query Query only Query only

Specifications

Introduction

Specifications describe the instrument's warranted performance after a 30-minute warm up period and the temperature compensation has been implemented, and are valid over the entire operating range unless otherwise noted.

Supplemental Characteristics are intended to provide additional information useful in applying the instrument by giving typical, but non-warranted performance parameters. These are shown in italics or labeled as "typical," "usable to," or "nominal."

Generator Output Path

(RF IN/OUT and RF OUT only connector)

NOTE:

To meet generator output path specifications, the input signal must be from the HP 8920A,B, HP 8921A,D, or HP 8924C Test Set with the following characteristics:
Frequency Range: 800 MHz to 995 MHz
Level Range: -70 dBm to -7 dBm.

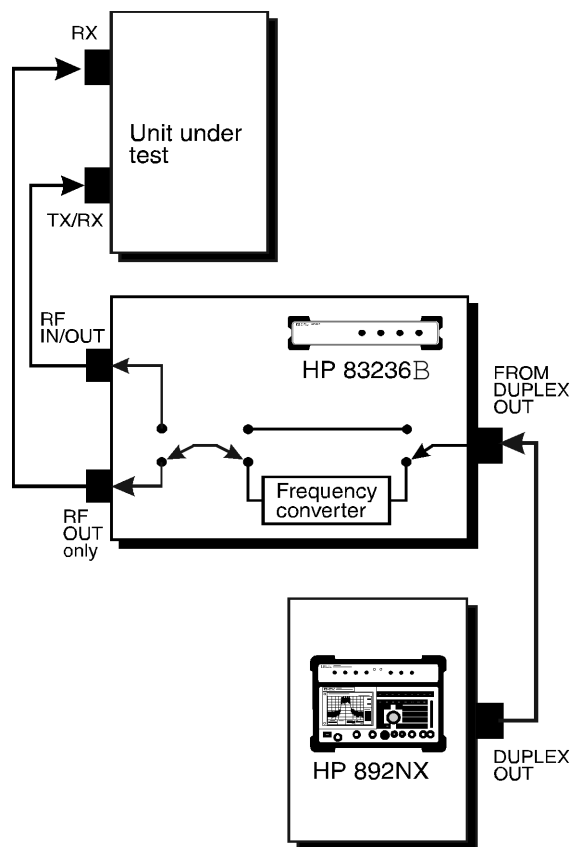

Figure 28

Block Diagram, Generator Output Path

Frequency

Frequency Range:

Through Path: 800 MHz to 960 MHz

Conversion Path:

1710 MHz to 1785 MHz

1805 MHz to 1910 MHz

1930 MHz to 1990 MHz

Frequency Settling Time:

<10 ms

Output

RF IN/OUT Port: -130 to -20 dBm

RF OUT only Port: -130 to -10 dBm

Output Level Accuracy:

$\pm 1.8 \text{ dB @ } 23 \text{ }^\circ\text{C} \pm 10 \text{ }^\circ\text{C}$

$\pm 2.0 \text{ dB @ } 0 \text{ }^\circ\text{C to } 55 \text{ }^\circ\text{C}$

$\pm 1.0 \text{ dB @ } 0 \text{ }^\circ\text{C to } 55 \text{ }^\circ\text{C}$

(See "Radiated Immunity:" on page 136.)

Output Level Settling Time: *<80 ms*

Spectral Purity

Table 13

Spurious

Type of spurious	800 to 960 MHz	960 < to <1710 MHz	1710 to 1990 MHz
Harmonics	< -30 dBc	—	< -30 dBc
Non-Harmonics	< -60 dBc*	< -25 dBc**	< -60 dBc*

* Offset \geq 5 kHz

** For carrier levels $>$ -100 dBm

SSB Phase Noise:

< -100 dBc/Hz at 20 kHz offset from carrier

Analyzer Input Path

(RF IN/OUT connector)

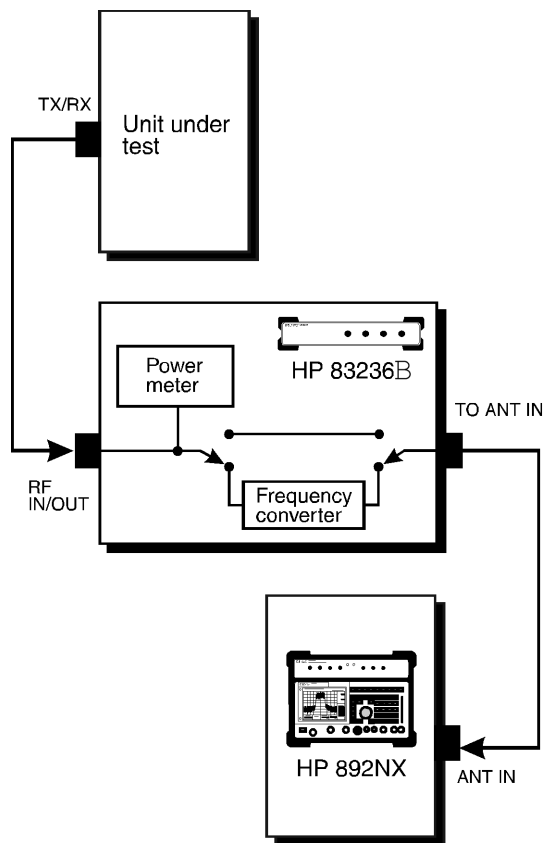

Figure 29 Block Diagram, Analyzer Input Path

Frequency

Frequency Range:

Through Path: 800 MHz to 960 MHz

Conversion Path:

1710 MHz to 1785 MHz

1805 MHz to 1910 MHz

1930 MHz to 1990 MHz

Input

Max Input Level:

Subscriber Unit Test

Single carrier TDMA and FM: 40 dBm (10 W)

CDMA: 37 dBm (5 W)

Base Station Test

Single carrier TDMA and FM: 40 dBm (10 W)

CDMA and multi-carrier: 30 dBm (1 W)

Max Peak Instantaneous Signal: 30 V

Spectral Purity

Integrated Spurious and Phase Noise:

<-57 dBc in a 100 Hz to 32 kHz bandwidth

Spurious Level: *<-60 dBc at ≥ 5 kHz and ≤ 20 MHz offset from carrier*

**Power
Measurement**

Frequency Range: 800 MHz to 960 MHz
1710 MHz to 1785 MHz
1805 MHz to 1910 MHz
1930 MHz to 1990 MHz

Measurement Range:

Subscriber Unit Test

Single carrier TDMA and FM:

-13 dBm to 40 dBm (50 μ W to 10 W)

CDMA:

-13 dBm to 37 dBm (50 μ W to 5 W)

Base Station Test

Single carrier TDMA and FM:

-13 dBm to 40 dBm (50 μ W to 10 W)

CDMA and multi-carrier:

-13 dBm to 30 dBm (50 μ W to 1 W)

Accuracy: $\pm 5\%$ of reading $\pm 2.5 \mu$ W @ 23 ± 10 °C after power meter zero and calibration

$\pm 10\%$ of reading $\pm 2.5 \mu$ W

Resolution 0.01 dB or 10 μ W

Reference Specifications

REF IN

Input Frequency: 10 MHz
Input Level Range: -5 dBm to +10 dBm

REF OUT

Output Frequency: 10 MHz
Output Level: -1 dBm
Accuracy: Buffered signal from REF IN, or 10 MHz \pm 10 ppm (if no external reference is connected to REF IN)

Remote Control

HP-IB Hewlett-Packard's implementation of IEEE Standard 488.2

SERIAL Port

Connector type: D-SUB15 (F)
Interface: RS-232C

Connectors

RF IN/OUT

(Input/Output to UUT)

Input /Output Impedance:	50 Ω (nominal)
Connector Type:	Type N (F)
SWR:	<1.2:1
Applied Power:	
Subscriber Unit Test	
Single carrier TDMA and FM:	40 dBm (10 W)
CDMA:	37 dBm (5 W)
Base Station Test	
Single carrier TDMA and FM:	40 dBm (10 W)
CDMA and multi-carrier:	30 dBm (1 W)
Max Peak Instantaneous Signal:	30 V

RF OUT only

(Output to UUT)

Output Impedance:	50 Ω (nominal)
Connector Type:	Type N (F)
SWR:	<1.6:1
Reverse Power:	200 mW CW max

Isolation between “RF IN/OUT” and “RF OUT only”

>40 dB

TO ANT IN

(Output to the Test Set)

Output Frequency Range:	650 MHz to 960 MHz
Output Impedance:	50 Ω (nominal)
Connector Type:	Type N (F)
SWR:	<2.3:1

FROM DUPLEX OUT

(Input from the Test Set)

Input Frequency Range:	800 MHz to 995 MHz
Input Level Range:	-70 dBm to -7 dBm
Input Impedance:	50 Ω (nominal)
Connector Type:	Type N (F)
SWR:	<1.3:1

REF IN

(Input from the Test Set)

<i>Input Frequency:</i>	<i>10 MHz</i>
Input Level Range:	-5 dBm to +10 dBm
Input Impedance:	50 Ω (nominal)
Connector Type:	BNC (F)

REF OUT

(Output)

<i>Output Frequency:</i>	<i>10 MHz</i>
<i>Output Level:</i>	<i>-1 dBm</i>
Output Impedance:	50 Ω (nominal)
Connector Type:	BNC (F)

EXT TRIG IN

(Input for TDMA)

External Trigger Signal:	Required for TDMA RF input level range -13 dBm to -5 dBm
Input Level:	TTL
Input Impedance:	> 1 k Ω at 1 MHz (nominal)
Triggering Type:	Positive Edge
Connector Type:	SMC (M)

DET OUT

(Output for CDMA)

Output impedance:	50 Ω (nominal)
Connector Type:	SMC (M)

General Characteristics

Size 84 H × 340 W × 500 D mm

Weight 5.6 kg

Operating Temperature
0 °C to 55 °C

Operating Humidity
15 to 95%RH @ 40 °C

Operating Altitude
0 to 2000 meters

Non-operating Temperature
−40 °C to 70 °C

Non-operating Humidity
to 90%RH @ 65 °C

Non-operating Altitude
0 to 4572 meters

Power AC 90 to 132 V, 198 V to 264 V
47 to 63 Hz
100 VA max

Others

Safety:

Complies with IEC 1010-1:1990+A1:1992 / EN 61010-1:1993

Certified by CSA-C22.2 No. 231-M89

EMC:

Radiated Emission:

Complies with EN 55011:1991 / CISPR 11:1990 - Group 1,
Class A

Voltage Fluctuations and Flicker:

Complies with EN 61000-3-3:1995 / IEC 1000-3-3:1994

Electrostatic Discharge:

EN 50082-1:1992 / IEC 801-2:1991 - 4 kV CD, 8 kV AD

Radiated Immunity:

EN 50082-1:1992 / IEC 801-3:1984 - 3 V/m

NOTE:

When tested at 3 V/m according to IEC 801-3/1984, the output level accuracy will be within specifications over the full immunity test frequency range of 26 to 1000 MHz except when the analyzer frequency is identical to the transmitted interference signal test frequency.

Electrical Fast Transient/Burst Immunity:

EN 50082-1:1992 / IEC 801-4:1988 - 0.5 kV Signal Lines,
1 kV Power Lines

Frequency Conversion Tables

Table 14 **Frequency Conversion Table for Signal Generation**

Desired Output at UUT Port [MHz]	LO Setting [MHz]	Required output from Test Set's DUPLEX OUT Port
800 to 960 MHz	bypass path	800 to 960 MHz
1710 to 1785 MHz	790 MHz	920 to 995 MHz
1805 to <1810 MHz	990 MHz	815 to <820 MHz
1810 to <1820 MHz	1000 MHz	810 to <820 MHz
1820 to <1830 MHz	1010 MHz	810 to <820 MHz
1830 to <1840 MHz	1020 MHz	810 to <820 MHz
1840 to <1850 MHz	1030 MHz	810 to <820 MHz
1850 to <1860 MHz	1020 MHz	830 to <840 MHz
1860 to <1870 MHz	1030 MHz	830 to <840 MHz
1870 to <1880 MHz	1040 MHz	830 to <840 MHz
1880 to <1890 MHz	1050 MHz	830 to <840 MHz
1890 to <1900 MHz	1060 MHz	830 to <840 MHz
1900 to 1910 MHz	1070 MHz	830 to 840 MHz
1930 to <1940 MHz	1060 MHz	870 to <880 MHz
1940 to <1950 MHz	1070 MHz	870 to <880 MHz
1950 to <1960 MHz	1080 MHz	870 to <880 MHz
1960 to <1970 MHz	1090 MHz	870 to <880 MHz
1970 to <1980 MHz	1100 MHz	870 to <880 MHz
1980 to 1990 MHz	1110 MHz	870 to 880 MHz

Table 15 **Frequency Conversion Table for Signal Analyzer**

Input Frequency from UUT [MHz]	LO Setting [MHz]	Required Input Frequency to Test Set's ANT IN port [MHz]
800 to 960 MHz	bypass path	800 to 960 MHz
1710 to <1758 MHz	1060 MHz	650 to <698 MHz
1758 to 1990 MHz	1050 MHz	708 to 940 MHz

B

Manual Changes

Introduction

This appendix contains revision notes for adapting the information in this manual to correspond to the PCS Interface units that were manufactured before this manual was printed. If the serial number of your PCS Interface matches one of the serial numbers noted on the inside cover of this manual, this manual can be used without referring to revision notes.

Manual Changes

After reviewing table 16 and table 17, write in this operation manual the necessary changes from the revision notes that correspond to the serial number of your PCS Interface or to the version of the firmware.

Not all of the information in this manual will be suitable for the PCS Interface units that are manufactured after this manual is printed. Yellow revision notes, inserted into this manual, will be included with such units when they are shipped from the factory.

If the serial number of your PCS Interface does not correspond to the numbers noted in the inside cover of this manual or those noted in table 16 and table 17, write down the changes in your operation manual corresponding to the yellow revision notes.

In addition to this information, the yellow revision notes also contain corrections to this manual. To keep your manual as accurate and up to date as possible we recommend that you periodically review the latest revision notes and update your manual accordingly.

If the serial number of your unit does not correspond to those in this manual or the yellow revision notes, contact the nearest Hewlett-Packard Sales Office.

To check the firmware version, execute an ***IDN?** command from an external controller. Refer to "***IDN?**" on page 98 for information on ***IDN?** command.

Table 16

Serial Number and Changes

Serial Prefix or Number	Changes

Table 17

Firmware Version and Changes

Version	Change
below REV.02.10	1

Serial Numbers

The serial number of your PCS Interface is marked on the serial number plate such as the one shown in figure 30. The plate is attached to the rear panel.



Figure 30

Serial Number Plate

Change 1

Change the following parts if the response to the query of the “*OPT” command is “NO OPTION”.

"COMPensation Subsystem" on page 100

COMPensation[:RFG1]:TEMPerature:FREQuency? []
 [{0|1|2|3|4|5}<numeric>[HZ|KHZ|MAHZ|MHZ|GHZ]]

This command returns the frequency required at the FROM DUPLEX OUT port for the temperature compensation for the RF signal generator to provide the optimum output level accuracy. If the frequency band or value is not specified, the frequency value specified by the **RX:OUTP:FREQ** is used. (Query only)

- 0:** 824 to 849 MHz band (Compensation frequency: 840 MHz)
- 1:** 869 to 894 MHz band (Compensation frequency: 880 MHz)
- 2:** 1710 to 1785 MHz band (Compensation frequency: 1750 MHz)
- 3:** 1805 to <1850 MHz band (Compensation frequency: 1830 MHz)
- 4:** 1850 to 1910 MHz band (Compensation frequency: 1880 MHz)
- 5:** 1930 to 1990 MHz band (Compensation frequency: 1960 MHz)
- <numeric>:** 824 to 849 MHz, 869 to 894 MHz, 1710 to 1785 MHz, 1805 to 1850 MHz, 1850 to 1910 MHz, 1930 to 1990 MHz (Compensation frequency is rounded off to 840 MHz, 880 MHz, 1750 MHz, 1830 MHz, 1880 MHz, or 1960 MHz.) If the entered value is out of range, the value is rounded off to the appropriate limit value. (The default unit is “Hz”.)

Supply the signal whose frequency and level are returned by this command and the **COMP:TEMP:LEV?** command to the FROM DUPLEX OUT port. Then execute the **COMP:TEMP:EXEC?** command to execute the RF generator temperature compensation.

- Response to the Query
 {numeric (Hz)} <new line><^END>

COMPensation[:RFG1]:TEMPerature:REQuest:STATe?
[[0|1|2|3|4|5]<numeric>[HZ|KHZ|MAHZ|MHZ|GHZ]]

Used to check if the RF generator compensations at the specified frequency band or value are required based on the temperature change since the last compensation. If the frequency band or value is not specified, the frequency value specified by the **RX:OUTP:FREQ** is used. This command measures the current temperature and compares it to the previously stored value. (Query only)

- 0:** 824 to 849 MHz band (Compensation frequency: 840 MHz)
- 1:** 869 to 894 MHz band (Compensation frequency: 880 MHz)
- 2:** 1710 to 1785 MHz band (Compensation frequency: 1750 MHz)
- 3:** 1805 to <1850 MHz band (Compensation frequency: 1830 MHz)
- 4:** 1850 to 1910 MHz band (Compensation frequency: 1880 MHz)
- 5:** 1930 to 1990 MHz band (Compensation frequency: 1960 MHz)
- <numeric>:** 824 to 849 MHz, 869 to 894 MHz, 1710 to 1785 MHz, 1805 to 1850 MHz, 1850 to 1910 MHz, 1930 to 1990 MHz (Compensation frequency is rounded off to 840 MHz, 880 MHz, 1750 MHz, 1830 MHz, 1880 MHz, or 1960 MHz.) If the entered value is out of range, the value is rounded off to the appropriate limit value. (The default unit is “Hz”.)

- Response to the Query

{0|1} <new line><^END>

- 0:** The temperature change is less than the value defined by the **COMP:TEMP:REQ:RES** command. The temperature compensation is *not* required.
- 1:** The temperature change is greater than the value defined by the **COMP:TEMP:REQ:RES** command. The temperature compensation is required.

"RX Subsystem" on page 108

RX[:RFG1]:OUTPut:FREQuency `[]` *<numeric>* `[HZ|KHZ|MAHZ|MHZ|GHZ]`

Specifies the frequency of the signal which you want to output from the RF IN/OUT or RF OUT only port.

<numeric>: 824 to 894 MHz, 1710 to 1785 MHz, 1805 to 1910 MHz, or 1930 to 1990 MHz. If the entered value is out of range, the value is rounded off to the appropriate limit value. (The default unit is "Hz".)

- Response to the Query

{numeric (Hz)} <new line><^END>

NOTE:

Use the **RX:TSET:FREQ?** command which has the functions of both the **RX:OUTP:FREQ** and **RX:INP:FREQ?** commands.

RX[:RFG1]:TSET:FREQuency? `[]` *<numeric>* `[HZ|KHZ|MAHZ|MHZ|GHZ]`

Specifies the frequency of the signal which you want to output from the RF IN/OUT or RF OUT only port, and returns the frequency required at the FROM DUPLEX OUT port, when the frequency of the wanted signal at the RF IN/OUT or RF OUT only is specified in **<numeric>**. (Query only)

<numeric>: 824 to 894 MHz, 1710 to 1785 MHz, 1810 to 1910 MHz, or 1930 to 1990 MHz (The default unit is "Hz".)

If the entered value is out of range, the value is rounded off to the appropriate limit value.

- Response to the Query

{numeric (Hz)} <new line><^END>

"TX Subsystem" on page 114

TX:INPut:FREQuency [] <numeric> [HZ|KHZ|MAHZ|MHZ|GHZ]

Specifies the frequency of the signal input to the RF IN/OUT port.

<numeric>: 824 to 894 MHz, 1710 to 1785 MHz, 1805 to 1910 MHz, or 1930 to 1990 MHz (The default unit is "Hz".)

If the entered value is out of range, the value is rounded off to the appropriate limit value.

- Response to the Query
{numeric (Hz)} <new line><^END>

NOTE:

Use the **TX:TSET:FREQ?** command which has the functions of both the **TX:INP:FREQ** and **TX:OUTP:FREQ?** command.

TX:OUTPut[:RFANalyzer]:PATH:IL? [] <numeric> [HZ|KHZ|MAHZ|MHZ|GHZ]

Returns the value of the insertion loss of the signal path for the RF signal analyzer, when the frequency of the input signal to the RF IN/OUT port is specified by <numeric>. This command is used to calculate the RF power using the Test Set. (Query only)

This command is valid only when the setting of **RF:PATH** is 1 or 2.

<numeric>: 824 to 894 MHz or 1710 to 1990 MHz (The default unit is "Hz".)

- Response to the Query
{numeric (dB)} <new line><^END>

TX:TSET:FREQuency? [] <numeric> [HZ|KHZ|MAHZ|MHZ|GHZ]

Performs the temperature compensation for the power detector, and returns the frequency which will be output to the TO ANT IN port, when the frequency of the input signal to the RF IN/OUT is specified in <numeric>. (Query only)

<numeric>: 824 to 894 MHz or 1710 to 1990 MHz (The default unit is "Hz".)

- Response to the Query
{numeric (Hz)} <new line><^END>

"Generator Output Path" on page 125

(RF IN/OUT and RF OUT only connector)

NOTE:

To meet generator output path specifications, the input signal must be from the HP 8920A,B, HP 8921A,D, or HP 8924C Test Set with the following characteristics:
Frequency Range: 810 MHz to 995 MHz
Level Range: -70 dBm to -7 dBm.

Frequency

Frequency Range:

Through Path: 824 MHz to 849 MHz

869 MHz to 894 MHz

Conversion Path:

1710 MHz to 1785 MHz

1805 MHz to 1910 MHz

1930 MHz to 1990 MHz

Spectral Purity

Table 18

Spurious

Type of spurious	824 to 849 MHz, 869 to 894 MHz	894 < to <1710 MHz	1710 to 1990 MHz
Harmonics	< -30 dBc	—	< -30 dBc
Non-Harmonics	< -60 dBc*	< -25 dBc**	< -60 dBc*

* Offset \geq 5 kHz

** For carrier levels > -100 dBm

"Analyzer Input Path" on page 128

(RF IN/OUT connector)

Frequency

Frequency Range:

Through Path: 824 MHz to 849 MHz

869 MHz to 894 MHz

Conversion Path:

1710 MHz to 1785 MHz

1805 MHz to 1910 MHz

1930 MHz to 1990 MHz

Power Measurement

Frequency Range: 824 MHz to 849 MHz

869 MHz to 894 MHz

1710 MHz to 1785 MHz

1805 MHz to 1910 MHz

1930 MHz to 1990 MHz

"Frequency Conversion Tables" on page 137

Table 19 Frequency Conversion Table for Signal Generation

Desired Output at UUT Port [MHz]	LO Setting [MHz]	Required output from Test Set's DUPLEX OUT Port
824 to 894 MHz	bypass path	824 to 894 MHz
1710 to 1785 MHz	790 MHz	920 to 995 MHz
1805 to <1810 MHz	990 MHz	815 to <820 MHz
1810 to <1820 MHz	1000 MHz	810 to <820 MHz
1820 to <1830 MHz	1010 MHz	810 to <820 MHz
1830 to <1840 MHz	1020 MHz	810 to <820 MHz
1840 to <1850 MHz	1030 MHz	810 to <820 MHz
1850 to <1860 MHz	1020 MHz	830 to <840 MHz
1860 to <1870 MHz	1030 MHz	830 to <840 MHz
1870 to <1880 MHz	1040 MHz	830 to <840 MHz
1880 to <1890 MHz	1050 MHz	830 to <840 MHz
1890 to <1900 MHz	1060 MHz	830 to <840 MHz
1900 to 1910 MHz	1070 MHz	830 to 840 MHz
1930 to <1940 MHz	1060 MHz	870 to <880 MHz
1940 to <1950 MHz	1070 MHz	870 to <880 MHz
1950 to <1960 MHz	1080 MHz	870 to <880 MHz
1960 to <1970 MHz	1090 MHz	870 to <880 MHz
1970 to <1980 MHz	1100 MHz	870 to <880 MHz
1980 to 1990 MHz	1110 MHz	870 to 880 MHz

Table 20 **Frequency Conversion Table for Signal Analyzer**

Input Frequency from UUT [MHz]	LO Setting [MHz]	Required Input Frequency to Test Set's ANT IN port [MHz]
<i>824 to 894 MHz</i>	bypass path	<i>824 to 894 MHz</i>
1710 to <1758 MHz	1060 MHz	650 to <698 MHz
1758 to 1990 MHz	1050 MHz	708 to 940 MHz

Error Messages

This section describes the error messages generated by the PCS Interface. These error messages are output through the HP-IB interface. A description of its contents and how to intervene to correct the error is provided for each error message.

When an error is generated, the PCS Interface issues an audible beep.

Error Messages

0	(No error) If an error was not generated and an error code was read at the HP-IB, '0' is returned.
100	Value out of range; Rounding occurred A numeric data parameter exceeded the range. Its value was rounded to a value within the range.
101	Index out of range; Command ignored The parameters of the commands were out of range.
102	Current path is invalid for the command The command that was sent could not be executed due to the current RF : PATH specification.
-100	Command error A general syntax error that could not be classified more specifically was generated. This occurs when a command error (defined in IEEE 488.2, 11.5.1.1.4) is generated.
-101	Invalid character A character that may not be used was included.
-102	Syntax error A command or data type that could not be recognized was used.
-103	Invalid separator A separator within a message (such as ; or ,) was invalid.
-104	Data type error The data type is invalid. This message would be displayed, for example, if an attempt was made to input numeric data where only character data should be input.

- 108 **Parameter not allowed**
- Too many parameters were contained in the command that was received.
- 109 **Missing parameter**
- The number of parameters in the command was not correct.
- 110 **Command header error**
- A header error was generated. This message is displayed if an error other than those corresponding to error codes -111 to -119 is generated.
- 111 **Header separator error**
- The header separator was incorrect. This message is displayed if a character other than those allowed in headers immediately follows a header. This message would be displayed if, for example, a character immediately followed a heading without a space between the heading and the character.
- 112 **Program mnemonic too long**
- There were too many characters in the command. (The maximum allowable number of characters in a command is 12.)
- 113 **Undefined header**
- Either an undefined header or an undefined command was sent.
- 114 **Header Suffix out of range**
- The unit of the header was out of the range. The header was made invalid due to the unit of the numeric parameter that immediately followed the command.
- 120 **Numeric data error**
- The cause of the error that was generated was numeric data (which may include numeric data that does not include a decimal point). This message is displayed if an error other than those corresponding to error codes -121 to -129 is generated.

Error Messages

-121	Invalid character in number
	Data other than numeric data was contained within numeric data.
-123	Exponent too large
	An exponent was too large. The largest allowable exponent is 32000. (See IEEE 488.2, 7.7.2.4.1.)
-124	Too many digits
	Numeric data was too long. (The maximum allowable length is 255 digits.)
-128	Numeric data not allowed
	Numeric data may not be used.
-130	Suffix error
	A unit suffix error.
	This message is displayed if a unit suffix error other than those corresponding to error codes -131 to -139 is generated.
-131	Invalid suffix
	The unit suffix could not be recognized or was invalid.
-134	Suffix too long
	The unit suffix was too long.
	This error is displayed if the unit suffix is 12 characters or more. (See IEEE 488.2, 7.7.3.4.)
-138	Suffix not allowed
	The unit suffix could not be used.
-140	Character data error
	A character data error.

This message is displayed if an error other than those corresponding to error code –144 or –148 is generated.

–141	Invalid character data
	Character data that was invalid or could not be recognized was sent.
–144	Character data too long
	Character data was too long. (The maximum allowable length is 12 characters.)
–148	Character data not allowed
	Character data may not be used.
–150	String data error
	Character data is not correct.
–151	Invalid string data
	Invalid character string data was sent.
	This message is displayed if, for example, the end code (END) is sent within string data delimited by quotation marks (" ").
–158	String data not allowed
	Character data may not be used.
–200	Execution error
	An execution error.
	This message is displayed if an execution error (defined in IEEE 488.2, 11.5.1.1.5) is generated.
–220	Parameter error
	A parameter error.

Error Messages

This message is displayed if an error is generated regarding the parameters other than those corresponding to error codes –221 to –229.

–221

Settings conflict

The settings conflict.

Program data could not be executed due to the current settings of the device. (See IEEE 488.2, 6.4.5.3 and 11.5.1.1.5)

–222

Data out of range

A numeric parameter of an HP-IB command is out of range.

–224

Illegal parameter value

The value of a parameter is inappropriate.

–225

Data out of memory

This device does not have enough memory to carry out the requested operation.

–230

Data corrupt or stale

The data is invalid. Data that was re-read was not read correctly in its entirety.

–231

Data questionable

The integrity of the data is questionable. The level of the precision of measurement data may be compromised.

- 240 **Hardware error**
- A hardware error.
- A program command could not be executed due to a hardware error. This message is displayed if an error other than those corresponding to error codes -241 to -249 is generated.
- 241 **Hardware missing**
- Hardware is missing.
- A program command could not be executed because a piece of equipment that should be connected to this device is missing. This error may be generated if an option is not installed.
- 310 **System error**
- A system error was generated.
- 311 **Memory error**
- A memory error. An error occurred in the memory of this device.
- 330 **Self-test failed**
- The result of the self-test was a failure. Contact the nearest HP sales office or service center, or refer to the *Service Manual* .
- 350 **Queue overflow**
- An error queue overflow.
- This error code was input in place of the error code corresponding to the original error. It indicates that the original error was not recorded because there was no available space in the error queue.

Error Messages

- 400 **Query error**
A Query command was invalid.
- 410 **Query INTERRUPTED**
A **DAB** or a **GET** command was received before the response to a Query command was completed.
- 420 **Query UNTERMINATED**
An incomplete program message was received after the specification was changed to 'TALK.'

Glossary

active link A two-way connection with a mobile phone. The Test Set provides a forward channel to the phone and monitors the reverse channel from the phone.

address (HP-IB) A means of identifying the location of instruments in the system for communication purposes. The default address for the PCS Interface is 719. See "1. HP-IB Address Selector" on page 26 for more information.

base station A fixed-location transceiver in a communications network. The land station in a cellular or PCS network carrying on a radio communication with subscriber units.

Cellular Adapter The HP 83201A,B, 83203B, 83204A, 83205A, or 83206A Cellular Adapter.

CDMA Code Division Multiple Access. A technique for spread-spectrum, multiple-access digital communication that creates channels through the use of unique code sequences.

downconverter A device in which the output frequency is the difference of the input frequency and a local oscillator frequency.

connectivity software A software program that is used to verify that the connections between equipment are correct and that the connecting cables are intact. The program also checks the basic functionality of each instrument in the Test System.

frame A basic timing interval. For CDMA access, paging, and traffic channels, a frame is 20 ms long; for the sync channel, a frame is 26.666...ms long. For TDMA a frame is 40 ms long.

frame clock A phase-locked loop in the Cellular Adapter that synchronizes the PCS Interface with the Cellular Adapter. The clock rate for CDMA and TDMA differ. Refer to the Cellular Adapter's *User's Guide* for further information.

CW Continuous wave. An RF carrier with no modulation.

HP-IB Hewlett-Packard Interface Bus. Hewlett-Packard's implementation of IEEE-488.2. Control of the PCS Interface is done through HP-IB.

IBASIC controller Instrument BASIC is the computer language used by the Test Set's built-in controller. The Test Set's built-in controller runs IBASIC programs to control the PCS Interface and perform automatic tests of radios.

local oscillator (LO) An oscillator whose output is mixed with the received signal to produce a sum or difference frequency equal to the intermediate frequency of the receiver.

mobile station A radio station designed to be installed in a vehicle or carried by a person and normally operated when in motion.

over-the-air Using the Test Set's protocol capabilities to establish and maintain an active voice/traffic channel (link).

Glossary

PCMCIA media A type of mass storage memory card. These cards can be static random access memory, read-only memory, or one-time programmable cards.

PCS Personal Communication Services

PCS frequency bands The International (1710 to 1880 MHz), Korean (1715 to 1870 MHz), and North American (1850 to 1990 MHz) PCS bands.

PCS Interface The HP 83236B.

port A place of access to a device where signals may be input, output, or measured. Also known as a connector or terminal.

procedure A file that customizes HP test software for a particular application.

reference, timebase A selected frequency from which frequency departure is measured. The reference frequency for the PCS Interface is 10 MHz. An external 10 MHz reference signal must be input to the PCS Interface's REF IN port because the interface does not have an internal reference source.

RX Abbreviation for receiver.

softkey Five inverse video fields that appear in the upper-right side of the Test Set's display. These fields correspond the USER keys on the Test Set's front panel. The softkey's function can be activated by pressing its corresponding USER key.

subscriber unit See **mobile station**.

terminal See **port**.

TDMA Time Division Multiple Access. A technique for increasing channel capacity by allowing up to six phone calls to time-share a channel.

temperature compensation A method of ensuring the accuracy of signal level and power measurements in the presence of fluctuating ambient temperatures. See "Temperature Compensations" on page 73 for more information about temperature compensation. See "Initialize the System" on page 77 through page 78 for temperature compensation programming commands.

Test Set The HP 8920, 8921, or 8924 Test Set.

Test System The PCS Interface, Test Set, and Cellular Adapter collectively.

trigger A pulse used to initiate some function, for this instrument, usually a power measurement. See "Set Up the Power Detector (for TX power measurements)" on page 86.

TX Abbreviation for transmitter.

upconverter A device in which the output frequency is the sum of the input frequency and a local oscillator frequency.

UUT Unit-Under-Test. The device that is being tested (usually subscriber unit or base station).

Symbols

*IDN?, 98
 *OPT?, 98
 *RST, 99

A

active link
 definition, 161
 address
 definition, 161
 ANT IN port, 24

B

base station
 definition, 161

C

CDMA
 definition, 161
 CDMA base station connections, 53
 cellular adapter
 definition, 161
 common commands, 92
 COMPensation Subsystem, 100
 configuration, stacking, 41, 42, 46, 47, 50, 51, 54, 55
 connections, 37, 40, 45, 50, 54
 CDMA base station, 53
 TDMA base station, 57, 58
 connections, verifying, 59
 connectivity software, 59
 definition, 161
 connector. See port.
 CW
 definition, 161

D

downconverter
 definition, 161
 DUPLEX OUT port, 24

E

error messages, 153

F

frame

definition, 161
 frame clock
 definition, 161
 front panel, 24
 furnished accessories, 19

H

HP-IB
 commands, 92
 connections, 63
 definition, 161
 Interface, 27

I

IBASIC controller
 definition, 161
 installation, 31

L

local oscillator
 definition, 161

M

manual changes, 141
 mobile station. See subscriber unit.

N

nominal, 124
 numeric, 96

O

options, 22
 over-the-air
 definition, 161

P

PCMCIA media
 definition, 162
 PCS
 definition, 162
 PCS frequency band
 definition, 162
 PCS Interface
 definition, 162
 placement, system, 34, 37, 40, 46, 50, 54
 port

definition, 162
 procedure
 definition, 162
 PULSE INPUT (TTL) port, 26

Q

query, 95

R

rear panel, 26
 REF IN port, 26
 REF OUT port, 26
 reference, timebase
 definition, 162
 RF subsystem, 106
 RX
 definition, 162
 RX port, 25
 RX subsystem, 108

S

serial numbers, 144
 softkey
 definition, 162
 specifications, 124
 subscriber unit
 definition, 162
 subsystem commands, 92
 abbreviations, 93
 suffixes, 96
 supplemental characteristic, 124
 supported configurations, 32
 SYSTem subsystem, 113

T

TDMA
 definition, 162
 TDMA base station connections, 57, 58
 temperature compensation
 definition, 162
 terminal. See port
 test set
 definition, 162
 test system
 definition, 162
 trigger
 definition, 162

Index

TX
definition, 162
TX subsystem, 114
TX/RX port, 25
typical, 124

U
upconverter
definition, 162

W
warm up time, 124